

TQC GRINDOMETER TOOL FOR AFA

AB3075



ANNEX F | GRINDOMETER TOOL FOR AFA

Dimensions

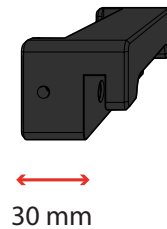
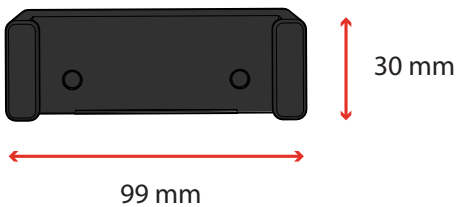
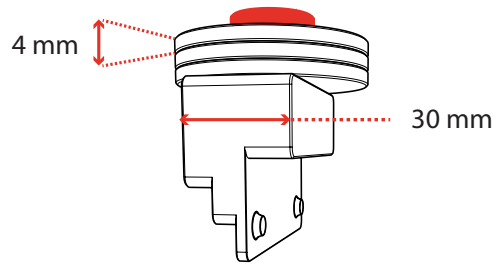
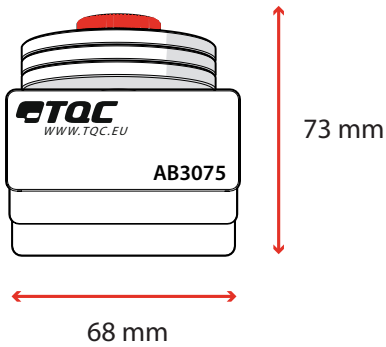
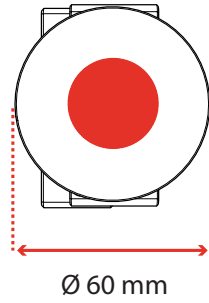

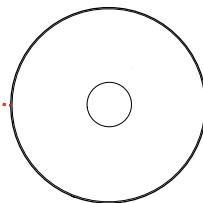
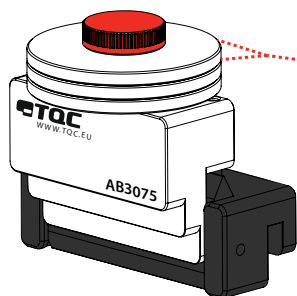
ANNEX F | GRINDOMETER TOOL FOR AFA**Weight**

100 g



805 g



114 g

ANNEX F | GRINDOMETER TOOL FOR AFA

Tool Operation

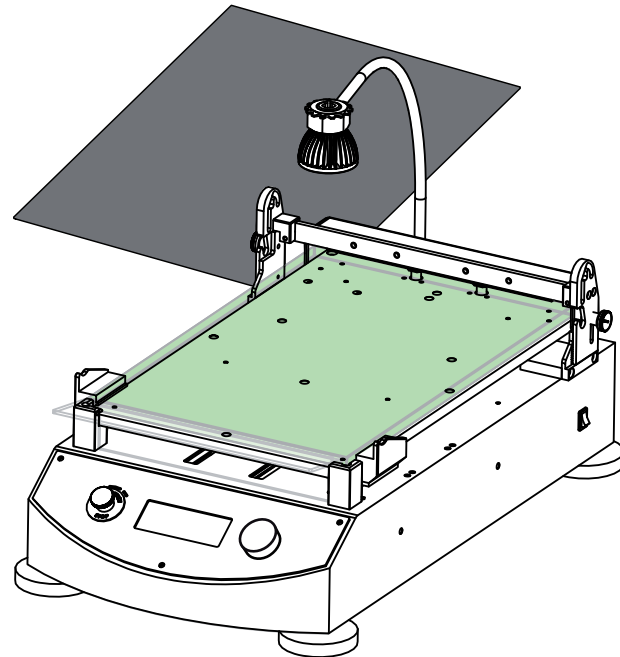

AB3075

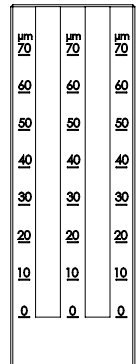
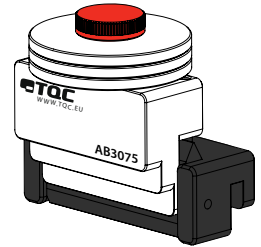

ANNEX F | GRINDOMETER TOOL FOR AFA

Setup

Settings

- Speed : 30 – 50 mm/s
- Length : Custom Start point - 0 mm / End point 160 mm
- Turn auto return off

See also 8.2

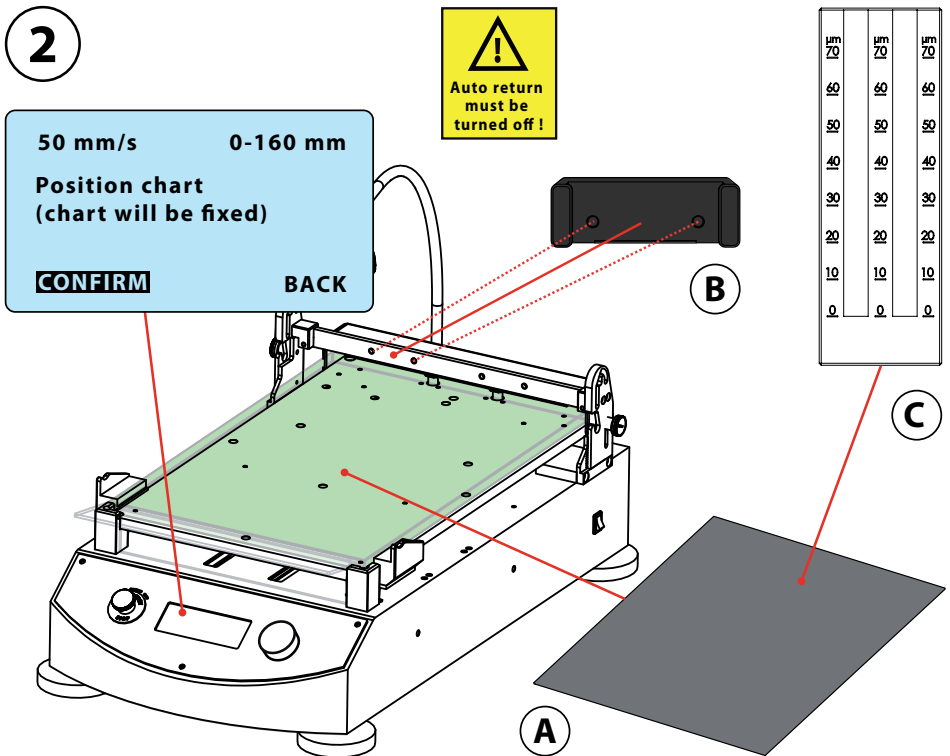

ANNEX F | GRINDOMETER TOOL FOR AFA

Height adjustment

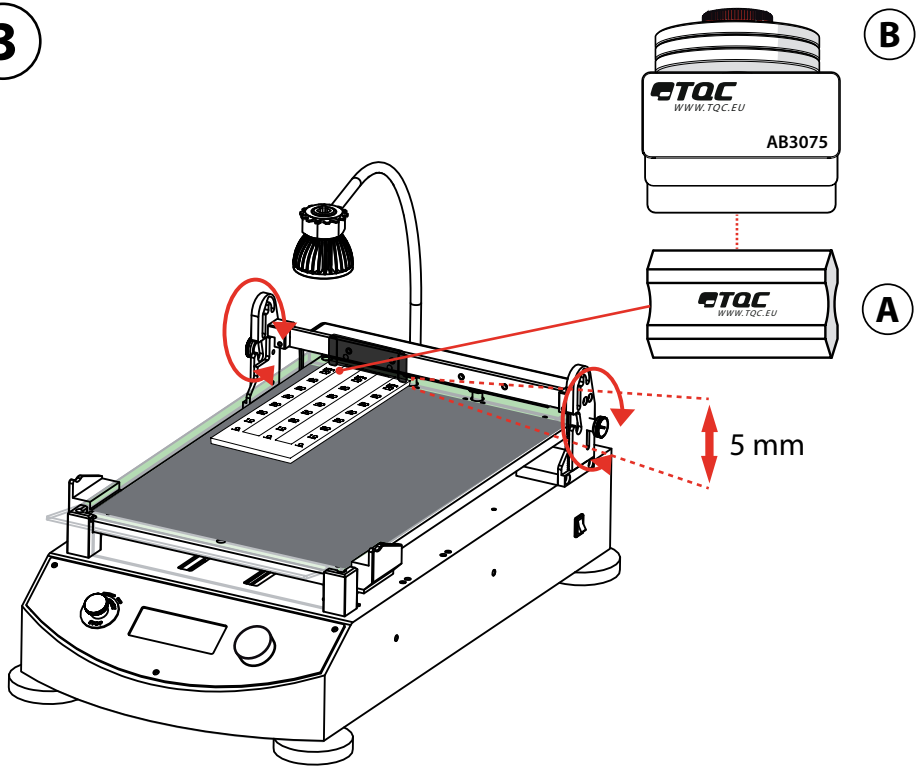
3

ANNEX F | GRINDOMETER TOOL FOR AFA

Drawdown

4

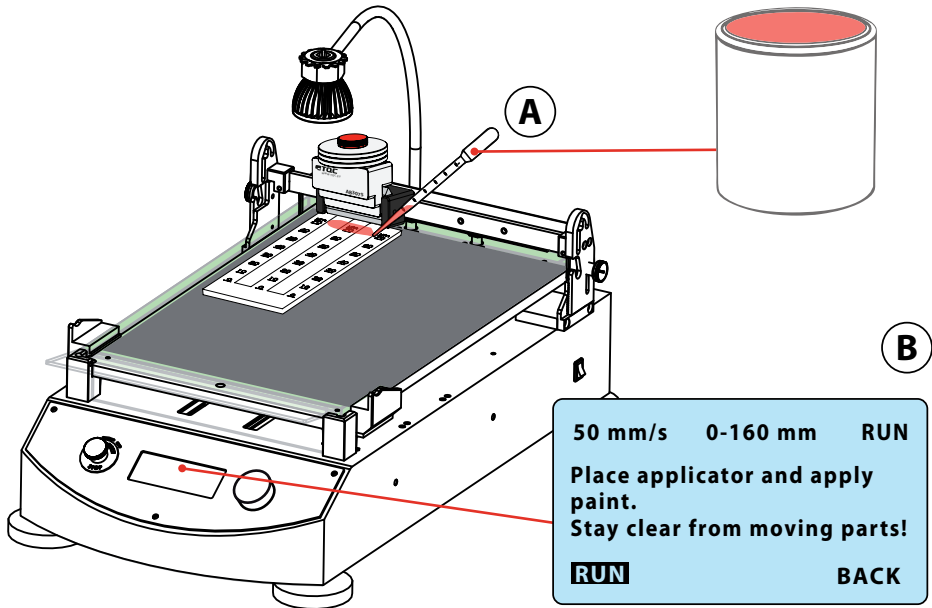

ANNEX F | GRINDOMETER TOOL FOR AFA

After drawdown

5