

# DIGITAL TORQUE WRENCH TESTER

## MODEL DOTE4-G

### OPERATING INSTRUCTION



To use this product properly and safely, please read this manual carefully before use. If you have any question about the product and its operations, please contact your nearest distributor or TOHNICHI Mfg. Co., Ltd.

## Safety Precautions

Before using this product, please read this operating instruction carefully to use it properly. If you have any question, please contact your nearest distributor or Tohnichi mfg. co., ltd. This operating instruction should be stored in a safe place.



### Safety Symbol

This symbol is used for drawing attention to "safety precautions". If you see this symbol in this operating instruction, attention should be paid to safety. Take preventative actions according to the description and conduct "safety operations and proper control".

"**⚠ Danger**" Indicates an imminently hazardous situation which, if not avoided, will result in death or serious injury.

"**⚠ Warning**" Indicates a potentially hazardous situation which, if not avoided, could result in death or serious injury.

"**⚠ Caution**" Indicates a potentially hazardous situation which, if not avoided, may result in minor or moderate injury.

### ⚠ Warning

- Stop using the product when smoke comes out or strange smell or unusual noise occurs. In such occasions immediately turn off the power, remove the AC adapter from the outlet and contact your nearest distributor or Tohnichi mfg. co.,ltd.
- Do not disassemble or modify this tester. It may result in loss of safety, degradation in functions, shortening of product life, or failure.
- Stop using the product when contaminant or liquid such as water is into main unit. You may be exposed to the danger of electric shock or fire.
- Do not use this tester with a power voltage other than that specified, AC100V-240V.
- When handling the power cable, follow the instructions below.
  - Do not handle the AC adapter with wet hand.
  - Do not damage, extend or heat the power cable.
  - Do not yank, pinch the power cable, nor put heavy objects on it.
  - Do not bend, twist nor bind the power cable by force.
  - Do not use the power cable for other purpose.
  - Do not use a damaged power cable of AC adapter.
- Do not place this tester on unstable place.
- Do not place this tester in a place where inflammable liquid or combustible gas is present.
- Use attached accessories. Do not use any other accessories.

### ⚠ Caution

- Do not put this tester in a place of much moisture or dust, in a place that is exposed to water or direct sunlight, or in a place where the humidity or temperature fluctuates largely. It may result in electric shock, fire, malfunction, degradation of performance or failure.
- Clean the AC adapter periodically. Before cleaning, disconnect the plug from power outlet and clean the root of the plug.
- If this tester is not to be used for a long time, be sure to disconnect the AC adapter from power outlet.
- Before moving this tester to another place, be sure to power off, remove the AC adapter and disconnect all connection cable. When moving the tester, avoid shock or vibration on it.
- Do not use this tester to conduct measurements beyond its capacity. For safe and efficient operation, use this tester to measure the torque wrenches suited to the capacity. Measurement beyond the capacity may cause accident or damage.
- Check for any damaged parts. Before use, check the tester and the accessories, and make sure that it operates normally and fulfills the specified functions. Check the parts and all other portions that may affect the operation for damage, installation status. For replacement or repair of damaged parts, contact your nearest distributor or Tohnichi mfg. co., ltd.

## Precautions for Use

Please operate this under recommended environment.

Do not disassemble or modify this tester.

Before use, make a start-up inspection and check the setting condition.

If this torque wrench tester gets wet with water or grease, it may bread down or burn out be careful not to drop water or grease.

Do not let this torque wrench tester fall or bump. It may result in damage or failure.

Use this torque wrench tester within the measurement range specified in the operating instruction.

Be sure to conduct a periodic inspection.

Before measurement, make sure that Zero is displayed.

Should the tester give out abnormal smell or catch fire during use, stop using immediately, move the tester to a safe place and contact your nearest distributor or Tohnichi mfg. co., ltd.

# Contents

---

1. Features .....	1
2. Components .....	1
3. Specifications .....	1
3-1. Common Specification .....	1
3-2. Dimensions .....	2
3-3. Torque Range and Accessories .....	3
4. External View .....	4
4-1. Display and Operation Keys .....	4
4-2. Power Source and Output .....	5
5. Function and Settings .....	6
5-1. RUN Mode, Continuous Value Display .....	6
5-2. PEAK Mode, Maximum Value Display .....	6
5-3. Upper/Lower Limit Value Selection .....	6
5-4. OK/NG Judgment and Data Memory .....	6
5-5. Auto Memory/Reset .....	6
5-6. Deletion of Data .....	6
5-7. Statistical Processing Function	
* Number of samples, Max-Mix-Mean Value .....	7
5-8. Auto Zero Adjustment .....	7
5-9. Over-Torque Alarm .....	7
5-10. Error Display .....	7
6. Various Settings .....	8
6-1. Setting Items .....	8
6-2. Registration of Upper- and Lower-limit Values .....	9
6-3. Parameter Settings .....	10
7. How to Calibrate Torque Wrenches .....	12
7-1. Calibration Conditions .....	12
7-2. Precaution in Calibration .....	12
7-3. Operation .....	17
8. External Output Function .....	17
8-1. Printer Output .....	19
8-2. PC Output .....	20
8-3. Operation with Communication Command .....	21
9. Optional Accessories .....	22
10. Error Message .....	23

## 1. Features

Model DOTE4-G is a digital torque wrench tester designed for calibrating or adjusting torque wrenches, and it has the following features:

- No need of torque wrench weight correction. The torque wrench to be measured is set horizontally, and weight adjustment is not necessary.
- Up to 1000 readings can be stored. The sampling number, maximum value, minimum value and average value of stored data can be displayed.
- Units of measure include Newton cN.m/N.m, Metric kgf.cm/kgf.m and American lbf.in/lbf.ft.
- The RS232C output terminal and USB, B-type output connectors allow the DOTE4-G to be interfaced to PC or Tohnichi printer.
- CE marking acquired. The DOTE4-G can be safely used in the EU.

## 2. Components

- Main Unit
- AC Adapter, BA-6
- Loading Plate
- Pole Assembly  
DOTE20N4-G unit has 2 sets
- Adapter Set
- Operating Instruction

## 3. Specifications

### 3-1. Common Specification

Display	LED height 11mm
Count Value	4 figures
Display Value	6 figures
Allow Mark Indication	RUN, Run Mode PEAK, Peak Mode M.R, Manual Memory/Reset A.R, Auto Memory/Reset Unit, cN.m/N.m/kgf.cm/kgf.m/lbf.in/lbf.ft
Output	Compliant with RS232C USB, B-type output connector for serial communication
Power Source	DC12V 1A
AC Adapter Power Source	AC100 to 240V +/-10%, 50/60Hz
Environmental Conditions	0 to 40 degree C Humidity below 85% RH, no condensation
Accuracy	+/-1%+1digit

### 3-2. Dimensions

#### DOTE20N4-G, 50N4-G, 100N4-G, 200N4-G

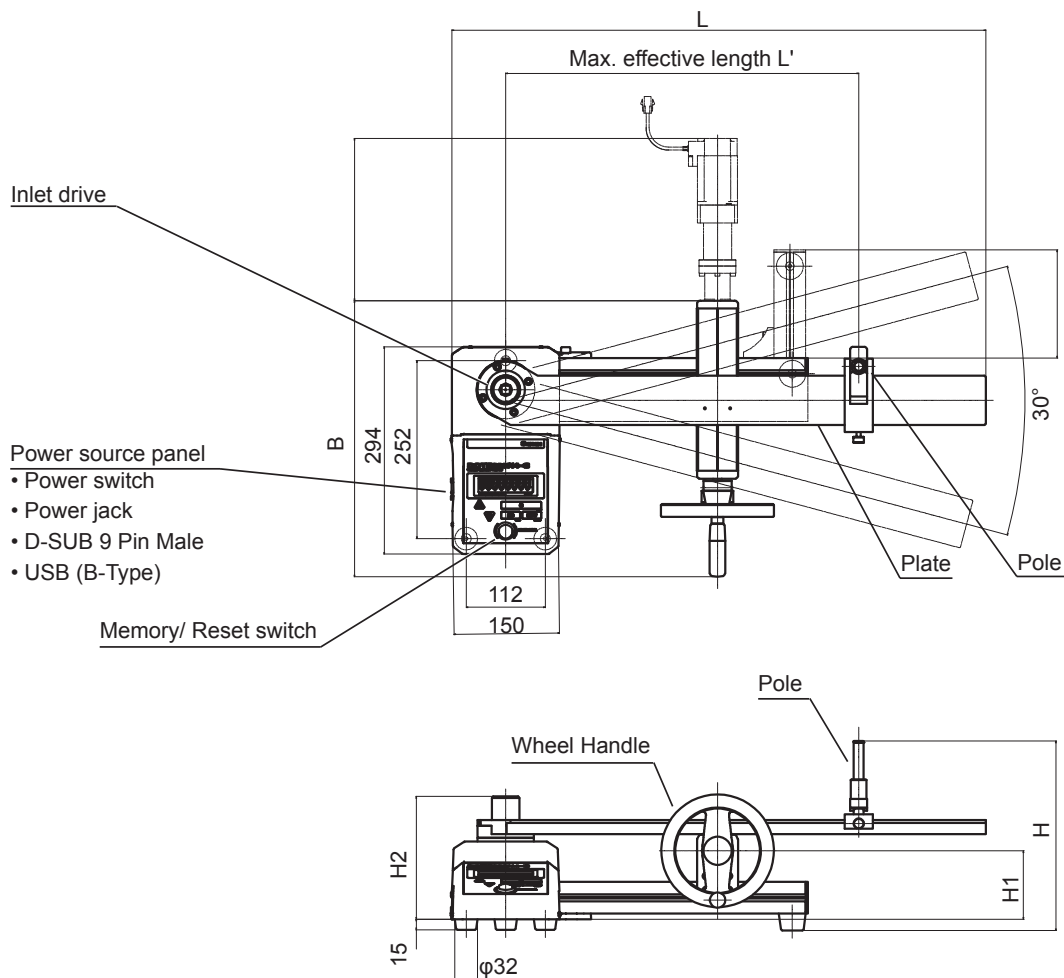

#### DOTE500N4-G, 1000N3-G

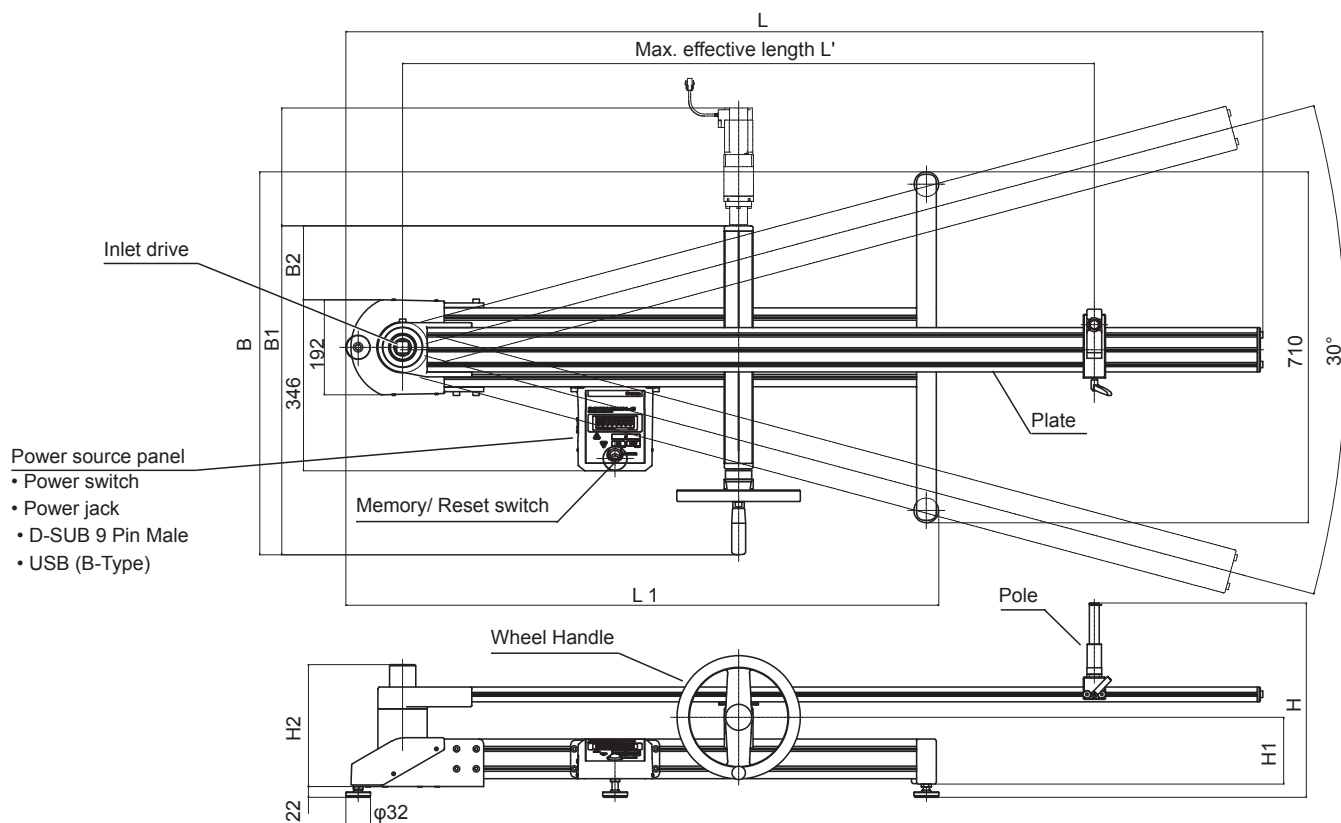

### 3-3. Torque Range and Accessories

Model		DOTE20N4-G	DOTE50N4-G	DOTE100N4-G	DOTE200N4-G	DOTE500N4-G	DOTE1000N4-G
cN·m	Range	200 - 2000	-	-	-	-	-
	1 Digit	0.2	-	-	-	-	-
N·m	Range	2 - 20	5 - 50	10 - 100	20 - 200	50 - 500	100 - 1000
	1 Digit	0.002	0.005	0.01	0.02	0.05	0.1
kgf·cm	Range	20 - 200	50 - 500	100 - 1000	200 - 2000	-	-
	1 Digit	0.02	0.05	0.1	0.2	-	-
kgf·m	Range	-	-	-	-	5 - 50	10 - 100
	1 Digit	-	-	-	-	0.005	0.01
lbf·in	Range	18 - 180	44 - 440	88 - 880	170 - 1700	440 - 4400	880 - 8800
	1 Digit	0.02	0.05	0.1	0.2	0.5	1
lbf·ft	Range	-	3.6 - 36	7.3 - 73	15 - 150	36 - 360	73 - 730
	1 Digit	-	0.005	0.01	0.02	0.05	0.1
Max. Effective Length L' [mm]		410			660	1100	1650
Inlet Drive [mm]		9.5		12.7		19.0	25.4
Dimension [mm]	L	506			756	1276	1856
	B	339			391	710	775
	H	267			269	394	
	L1	-				805	1195
	B1	-				518	666
	B2	-				90	150
	H1	113				162	
	H2	171		169		174	238
Weight [kg]		12			13	47	49
Accessory	Down Adapter	DA3-2		277 (Sq.1/2-Inlet 1/4) DA4-3	-	-	DA8-6
	Hex Adapter	10-13-19		12-14-17		17-22-27 19-24-30	22-27-29 30-32-36

Accuracy +/-1% +1digit

#### Down Adapter, DA Specification

Model	Parts#	Dimension [mm]				Allowable Torque [N·m]	Weight [g]
		Sq. Drive	Inlet Drive	Height	Outside Width		
DA3-2	296	9.5	6.35	12	13	14	5
DA4-3	297	12.7	9.5	15	18	70	11
DA6-4	298	19.0	12.7	19	28	220	34
DA8-6	299	25.4	19.0	26	35	750	66
DA12-8	300	38.1	25.4	44	55	2100	320

# 4. External View

## 4-1. Display and Operation Keys

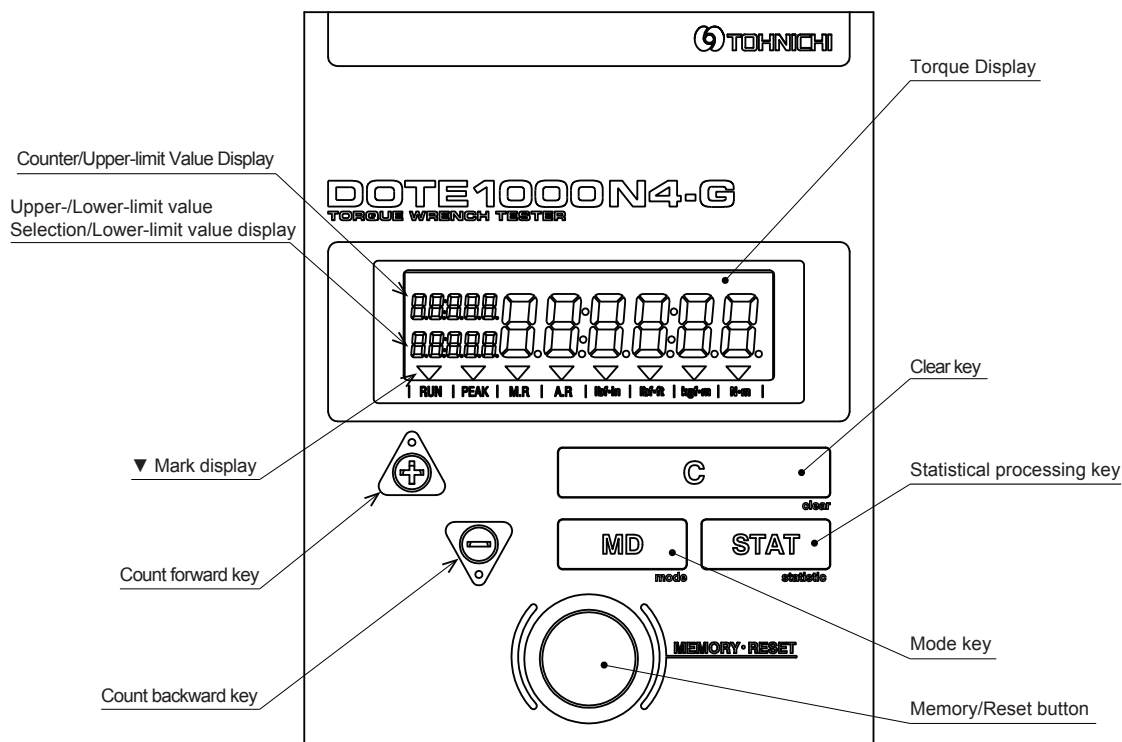

Display	Torque Display area indicates the torque value. Values are displayed in blue when an OK/NG judgment result is OK, in red when it is LO/HI, and in white when no OK/NG Judgment is made.
Counter/Upper-limit Value display	Display a serial number or an upper-limit value.
Upper-/Lower-limit value Selection/Lower-limit value display	Displays an upper-/lower-limit value selection status for OK/NG Judgment or a lower-limit value.
▼ Mark display	<p>RUN Lights up when RUN mode (Continuous display) is selected.</p> <p>PEAK Lights up when PEAK mode (Maximum value display) is selected.</p> <p>M.R Lights up when Auto memory/Reset is not set in the PEAK mode. Lights up in the RUN mode.</p> <p>A.R Lights up when Auto memory/Reset is set in the PEAK mode.</p> <p>Unit ▼ appears on the unit (lbf·in, lbf·ft, cN·m, N·m, kgf·cm, kgf·m) selected.</p>
Count forward Key	Moves the counter forward by one to read out measured data
Count backward Key	Moves the counter backward by one to read out measured data
Clear Key	In the PEAK mode, the peak value is reset. Or, the stored data is cleared. In the RUN mode, auto zero adjustment is performed.
Statistic processing Key	This is a key for selecting the number of samples, maximum value, minimum value or mean value.
Mode Key	This is a key for selecting the RUN mode or PEAK mode. The upper-/lower-limit value selection screen is displayed by holding down the key for 2 seconds or longer.
Memory/Reset button	Stores the measured data (measured torque, measurement date and time) and moves the counter forward by one after OK/NG Judgment of the measured data.

## 4-2. Power Source and Output

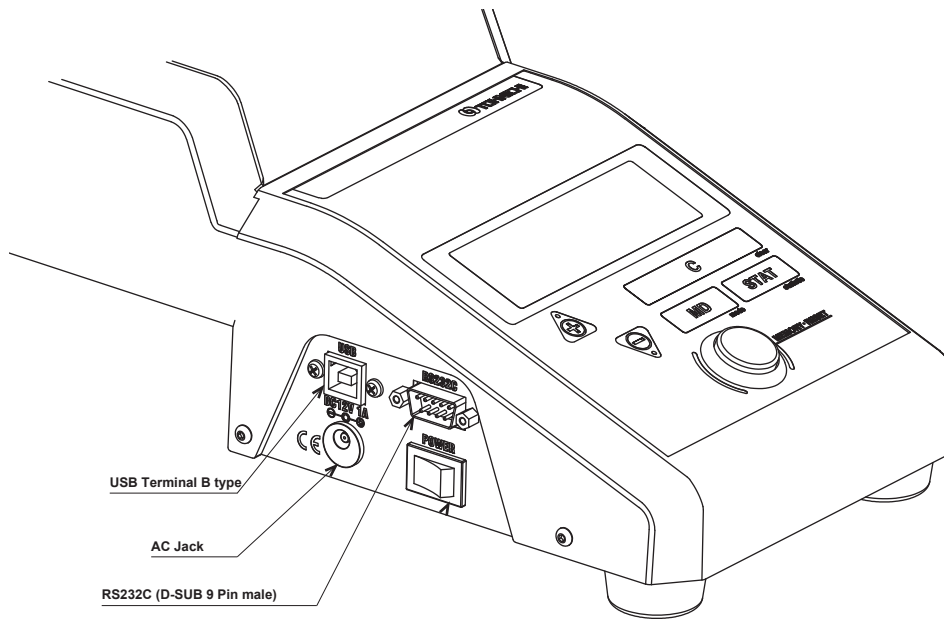

**DOTE20N4-G, 50N4-G, 100N4-G, 200N4-G**

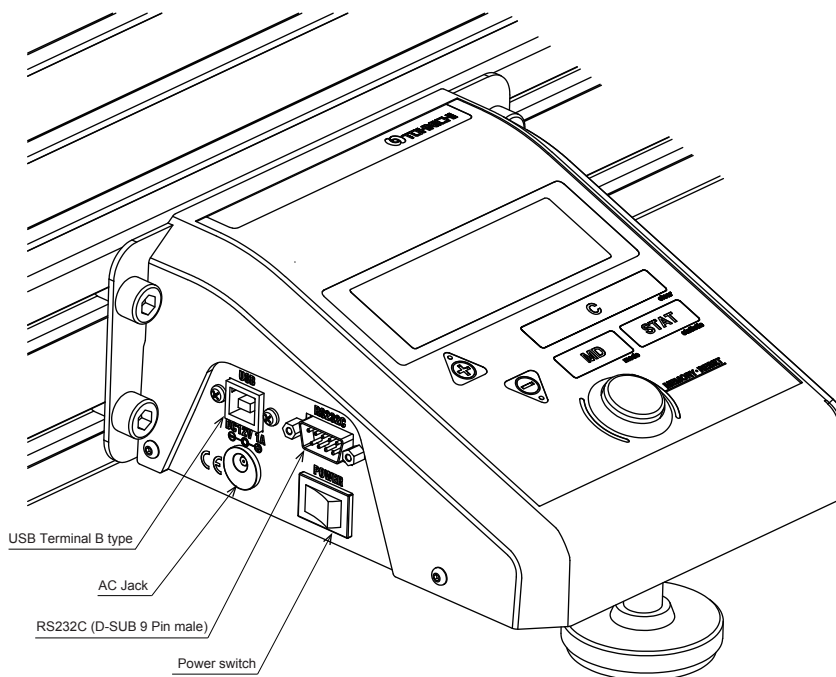

**DOTE500N4-G, 1000N4-G**

- DC power jack, 12V-1A-Center positive: Connect the attached AC adapter BA-6.
- Power switch: Turns the power ON / OFF.
- RS232C terminal: Connect an RS232C communication cable.
- USB B-type connector for serial communication: Connect a USB communication cable.
- Do not connect RS232C and USB output connectors externally at the same time.



## 5. Functions and Settings

### 5-1. RUN Mode, Continuous Value Display

Torque value on display increases by loading torque and returns to 0 when load is released.

RUN mode is mainly used for measuring direct reading type torque wrench. Press "MD" key to change between RUN and PEAK mode. ▼ on RUN is RUN mode condition.

### 5-2. PEAK Mode, Maximum Value Display

Torque value on display increases by loading torque, and will keep the maximum torque on the display even after releasing the load. PEAK mode is mainly used for measuring click type torque wrench.

Press "MD" key to change between RUN and PEAK mode. ▼ on PEAK is PEAK mode condition.

### 5-3. Upper/Lower Limit Value Selection

#1 Press "MD" key for two seconds.

#2 Using ▼ or ▲ key, select registered Upper-/Lower-limit values.

#3 Press "STAT" key to select, and back to measurement mode. Press "MD" key for cancellation.

For registration of the upper- and lower-limit values, refer "Section #6. Various Settings".

### 5-4. OK/NG Judgment and Data Memory

When press "Memory/Reset" button or Auto Memory/Reset function is acting, OK/NG Judgment is performed. OK result is displayed in blue color for 0.5 second, and NG in red for one second.

Results are stored up to 1,000.

Decision Criteria HI: Registered upper limit value < Result torque value

OK : Lower limit value  $\leq$  Result torque value  $\leq$  Upper limit value

LO : Result torque value < Registered lower limit value

### 5-5. Auto Memory/Reset

When load is released, peak torque value will be displayed for between 0.1 to 5.0 seconds.

Value will then be stored and display will return to zero for the next operation.

### 5-6. Deletion of Data

#### #1 Delete one data:

Use ▼/▲ keys to show data for deletion, and press "C" key. The data is deleted.

#### #2 Delete data between two selected results:

Use ▼/▲ keys to select the last result which is to be deleted, then press the "STAT" key to show "Stt" on display. While "Stt" and count "1" is shown, press ▼ key to show serial number of the selected last result.

Push ▼/▲ keys to select the serial number which is the beginning result to be deleted, and press "STAT" key to make a selection.

Total data stored number of the section is shown as "n". With each push of the "STAT" key, "n", "HI", "Lo" and "Av" is displayed in order. While these statistical number shown on, press "STAT" first and "C" keys.

The selected data section will be deleted.

#### #3 Delete all stored data:

Turn on its main switch while pressing the "Memory/Reset" button. "CLEAR" is displayed at the start-up time, clearing all the data.

**Caution:** Before delete data, make sure whether or not the data should be deleted.

### 5-7. Statistical Processing Function, Number of samples, Max-Min-Mean Value

#1 Use ▼/▲ keys and show the last result of the section for statistical processing.

#2 Press “STAT” key to show “Stt” on display. And use ▼/▲ keys to show the first result of the section.

Press “STAT” key and the sampling number “n”, maximum value “HI”, minimum value “Lo” and mean value “Av” in the specified data range are displayed in order.

### 5-8. Auto Zero Adjustment

With no load on the tester, Auto Zero function is performed automatically by press “C” key or turn the power OFF/ON switch.

#### “Err9” on display

When loading torque exceeds more than 5% of the tester's maximum torque range, “Err9” is displayed.

When “Err9” is displayed, press “C” key with no load on the tester. “Err9” message disappears.

If “Err9” message is still on the display, turn off and on again.

Torque sensor or the electric circuit board may have any problem if “Err9” shows again.

### 5-9. Over-Torque Alarm

When loading torque exceeds 110% of its maximum torque range, the display flashes as a warning.

### 5-10. Error Display

DOTE4-G has a self-diagnosis function. When a problem occurs, any of the error messages from Err1 to 9 is displayed.

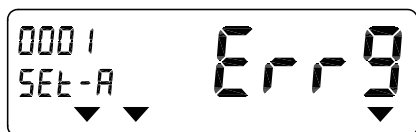

For any other error messages, refer to "Section #10. Error Message"

# 6. Various Settings

## 6-1. Setting items

Item	Counter Upper limit Value Display	Upper/Lower-limit Value Selection/ Lower-limit Value Display	Main Display		
			Factory Default	Selectable range	
1	Setting item selection	--		torq-S	PARA-S
2	Measurement unit	Unit		N·m	4 units
3	A Upper-limit value	HI	SEt-A	0	0 to Maximum Range
4	A Lower-limit value	Lo	SEt-A	0	0 to Maximum Range
5	B Upper-limit value	HI	SEt-b	0	0 to Maximum Range
6	B Lower-limit value	Lo	SEt-b	0	0 to Maximum Range
7	C Upper-limit value	HI	SEt-C	0	0 to Maximum Range
8	C Lower-limit value	Lo	SEt-C	0	0 to Maximum Range
9	D Upper-limit value	HI	SEt-d	0	0 to Maximum Range
10	D Lower-limit value	Lo	SEt-d	0	0 to Maximum Range
11	E Upper-limit value	HI	SEt-E	0	0 to Maximum Range
12	E Lower-limit value	Lo	SEt-E	0	0 to Maximum Range
13	F Upper-limit value	HI	SEt-F	0	0 to Maximum Range
14	F Lower-limit value	Lo	SEt-F	0	0 to Maximum Range
15	G Upper-limit value	HI	SEt-g	0	0 to Maximum Range
16	G Lower-limit value	Lo	SEt-g	0	0 to Maximum Range
17	H Upper-limit value	HI	SEt-H	0	0 to Maximum Range
18	H Lower-limit value	Lo	SEt-H	0	0 to Maximum Range
19	I Upper-limit value	HI	SEt-I	0	0 to Maximum Range
20	I Lower-limit value	Lo	SEt-I	0	0 to Maximum Range
21	J Upper-limit value	HI	SEt-J	0	0 to Maximum Range
22	J Lower-limit value	Lo	SEt-J	0	0 to Maximum Range

Item	Counter/Up- per-limit Value Display	Main Display		
		Factory Default	Selection item	
1	Automemory/reset	Ar	0	0.1/0.2/0.3/0.4/0.5/1.0/2.0/3.0/4.0/5.0
2	Keyoperationsound	bU	on	oFF
3	External output	doUt	PC	Prn
4	Baud rate	bPS	115200	19200/9600/4800/2400
5	Data length	LngtH	8bit	7bit
6	Parity	PARty	nonE	odd/EVEN
7	Memorymode	dCnt	1000	99
8	Default	dFLt	dFLt-n	dFLt-y

## 6-2. Registration of Upper and Lower limit Values

### Setting screen reading

In measurement screen, press “C”–“STAT”–“MD” keys in order. After “- - -” appears on display, you will enter the selection screen.



### Setting item selection

Register Upper/Lower limit values and select measuring unit for DOTE4-G models. During “torq-S” on display, press the “MD” or “STAT” key to proceed to the next item. Press “C” key to return to the measurement display mode without making any setting.

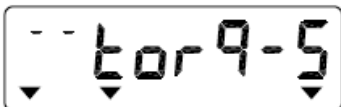

### Measurement unit setting

Select desired measuring unit by ▼/▲ keys, and press the “STAT” key to set. Press “MD” key to skip the setting. Press “C” key to go back to the measurement mode.

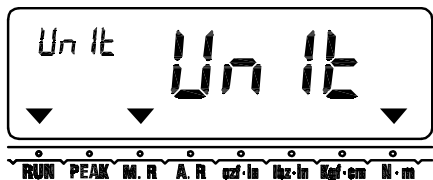

Factory Default Setting : N·m scale

Unit Conversion Table

	Conversion factors	
N·m to <a href="#">kgf·cm</a>	10.1972	$100.0N.m \times 0.73756 = 73.756 = \text{73.8lbf.in}$ $\text{73.8lbf.in} \div 0.73756 = 100.05 = 100.1N.m$ Converted figures are rounded as above. Accordingly, the resulted figures may have a margin of errors. Unit conversion is made based on N·m values with the above conversion factors.
N·m to kgf·m	0.010972	
N·m to <a href="#">lbf·in</a>	8.858	
N·m to lbf·ft	0.73756	

All the saved data and torque setting values will be converted when making a unit change

### Upper limit value registration for OK/NG judgment

Pick each digit by ▲ key and select a number by ▼ key, and register by “STAT” key. Press “MD” key, and skip the setting. Press “C” key to go back to the measurement mode. If a value exceeding the tester's maximum torque range is registered, “SEtErr” message appears on display, and return to the beginning.



### Lower-limit value registration for OK/NG judgment

Pick each digit by ▲ key and select a number by ▼ key. Press “STAT” key to register the value, and next registration. Press “MD” key to skip the setting. Press “C” key and back to the measurement mode. If a value exceeding the tester’s maximum torque range or more than registered upper limit value are registered, “SEtErr” message appears on display, and return to the beginning.



Subsequently, register Upper/Lower limit values until “J”. Back to measurement mode after “J” setting automatically. Also, to press “C” key, back to measurement mode from any stage.

Delete all existed torque results before setting Upper/Lower limit values. If changes Upper/Lower limit values, OK/NG function makes a judgment on stored data with new registered limits.

### 6-3. Parameter Settings

#### Setting screen reading

In the measurement screen (no-load), press “C”–“STAT”–“MD” keys in order. After “- - -” appears on display, you will enter the selection screen.

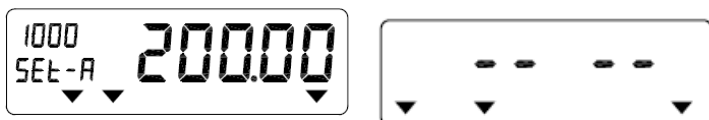

#### Setting item selection

Use ▲/▼ keys to change from “torq-S” to “PARA-S” on display. Press “MD” or “STAT” key to proceed to the next. Press “C” key to return to the measurement display mode immediately.



#### Auto memory/reset setting

Use ▲/▼ keys and select any time between 0.1 to 5.0 seconds. Press “STAT” key to enter. To set manual memory/reset function, select “0.0” time. Press “MD” key to skip the setting. Press “C” key to go back to the measurement mode.



Factory Default Setting : 0.0

#### Key operation buzzer setting

Use ▲/▼ keys and select “on” or “off”. Press “STAT” key to enter. Press “MD” key to skip the setting. Press “C” key to go back to the measurement mode.

Even in buzzer off condition, “over-torque” alarm sound occurs.

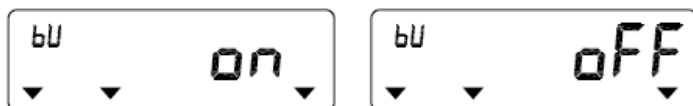

Factory Default Setting : on

#### Communication setting

##### #1 Output format setting (Factory default: PC output)

Use ▲/▼ keys and select “Prn” for printer output or “PC” for PC. Press “STAT” key to enter, and go to next setting, “Baud Rate Setting”. Press “MD” key to skip the setting. Press “C” key to go back to the measurement mode.

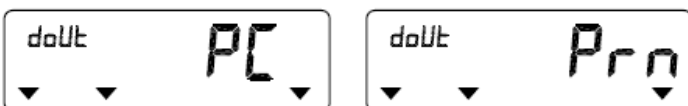

Factory Default Setting : PC output

##### #2 Communication baud rate setting

Use ▲/▼ keys and select “115200”, “19200”, “9600” or “2400”. Press “STAT” key to enter and go to next setting, “Data length setting”. Press “MD” key to skip the setting. Press “C” key to go back to the measurement mode.

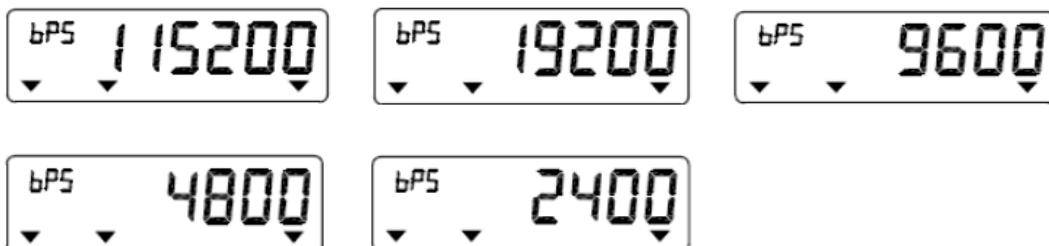

Factory Default Setting : 115200

### #3 Data length setting

Use ▲/▼ keys and select “7bit” or “8bit”. Press “STAT” key to enter and got to next setting, “Parity Setting”. Press “MD” key to skip the setting. Press “C” key to go back to the measurement mode.



Factory Default Setting : 8bits

### #4 Parity setting

Use ▲/▼ keys and select “nonE” for none, “EVEN” for even number or “odd” for odd number. Press “STAT” key to enter and go back to the measurement mode. Press “MD” key to skip the setting. Press “C” key to go back to the measurement mode.

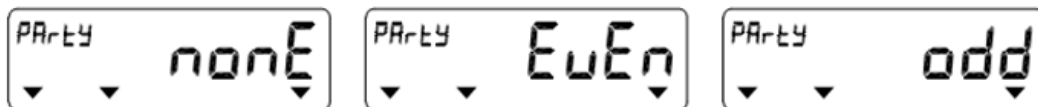

Factory Default Setting : None

### Memory mode setting

Set a measured data memory capacity.

“1000”: 1,000 data memory

“99”: 99 data memory, communication format compatible with previous DOTE3-G model



Factory Default Setting : 1000

Use ▲/▼ keys and select 1000 or 99. Press “STAT” key to go confirmation screen. Press “MD” key to skip the setting. Press “C” key to go back to the measurement mode.

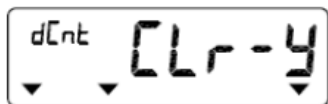

Press “STAT” key to confirm. Memory mode is changed and all stored data is cleared.

When memory mode is changed, existed memory is cleared. Press “C” key to go back.

### Default setting

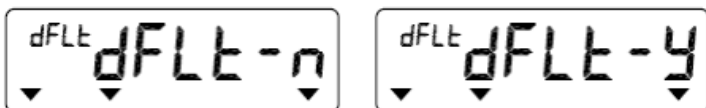

Use ▲/▼ keys to select “dFLt-Y”. Press “STAT” key to reset to the factory default settings. Press “MD” key to skip the setting. Press “C” key to go back to the measurement mode.

## 7. How to Calibrate a Torque Wrench

### 7-1. Calibration Conditions

#### 7-1-1. Calibration temperature

Calibration shall be performed at the ambient temperature in the 18 to 28°C range.  
Temperature variations shall be within  $\pm 1^\circ\text{C}$ .

#### 7-1-2. Check the following points before starting calibration of a torque wrench.

- (1) Place the torque wrench tester on a stable workbench.
- (2) For direct-reading type torque wrenches, read the measurement value in a direction perpendicular to the scale or dial (Parallax correction).
- (3) For click-type torque wrenches (QL/SP, etc) do a warm-up operation by loading the maximum torque of each model for both directions 5 times before testing.
- (4) For direct-reading type torque wrenches (CEM/DB/F type, etc), do a warm-up operation by loading the maximum torque of each model for both directions once, and make sure the pointer, or the digital display shows "0" after loading.
- (5) Apply load at the center of the grip or at the marked loading point within the specified range in Fig. 1.

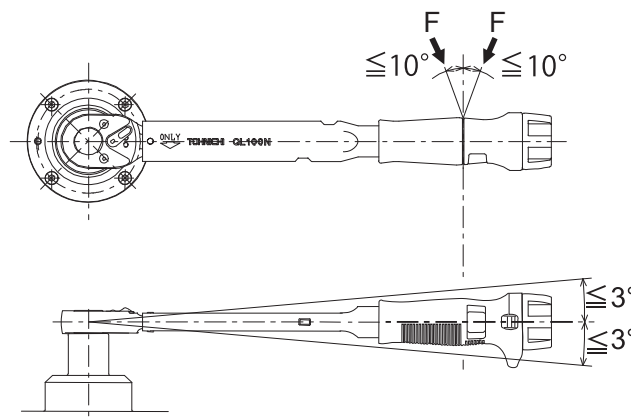

Fig. 1.

### 7-2. Precautions in Calibration

- (1) For click-type torque wrenches (QL/SP, etc), load the initial torque up to 80% of the target torque, then apply the rest slowly and evenly. (take 1 - 3 seconds to apply the last 20%.) Pre-set type torque wrench (except single-purpose type such as QSP) must start at low level, then adjust to the target torque. (Do not adjust to the target torque by lowering from the higher level.)
- (2) For direct-reading type torque wrenches (CEM/DB/F, etc), apply torque up to the target torque with attention not to exceed the target torque.  
If you exceed the target torque by mistake, please release torque down to zero and do the process from scratch.

### 7-3. Operation

- (1) Place DOTE4-G on a horizontal sturdy workbench.
- (2) Put Operation Sticker on DOTE4-G.
- (3) Put the Plate on to DOTE4-G and fix the Plate with the set screw on the side.

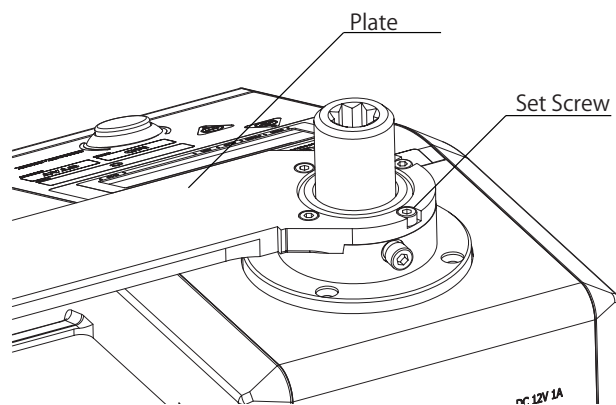
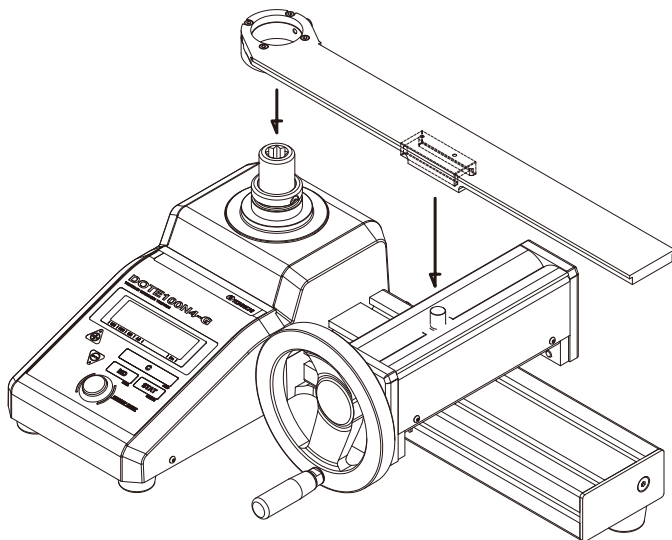

- (4) Place the Pole Holder Assembly on the Plate.

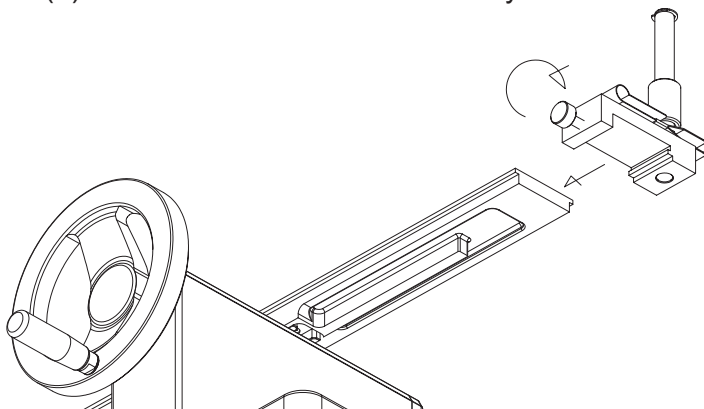

- (5) Connect the attached AC adapter to DOTE4-G and confirm that power switch is turned off. Then, insert the plug of the power cable into an power supply receptacle.

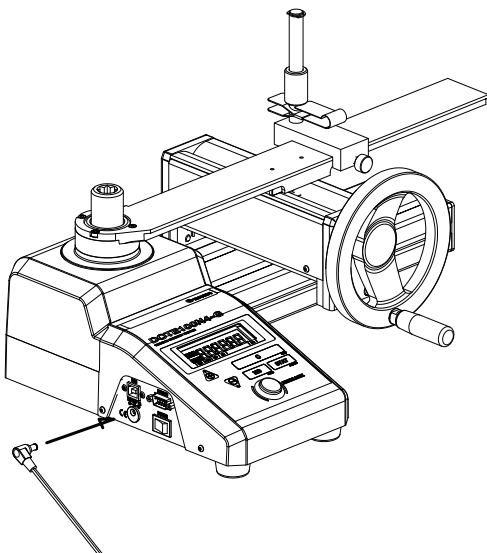



- (6) Turn the power switch on.  
Before using, leave it on for at least 30 minutes for stabilization.
- (7) Set each mode. Auto memory/reset, communication setting.  
For the setting instructions, refer to section "5. Functions and Settings".
- (8) Select adapter or socket based on the torque wrench to be calibrated.

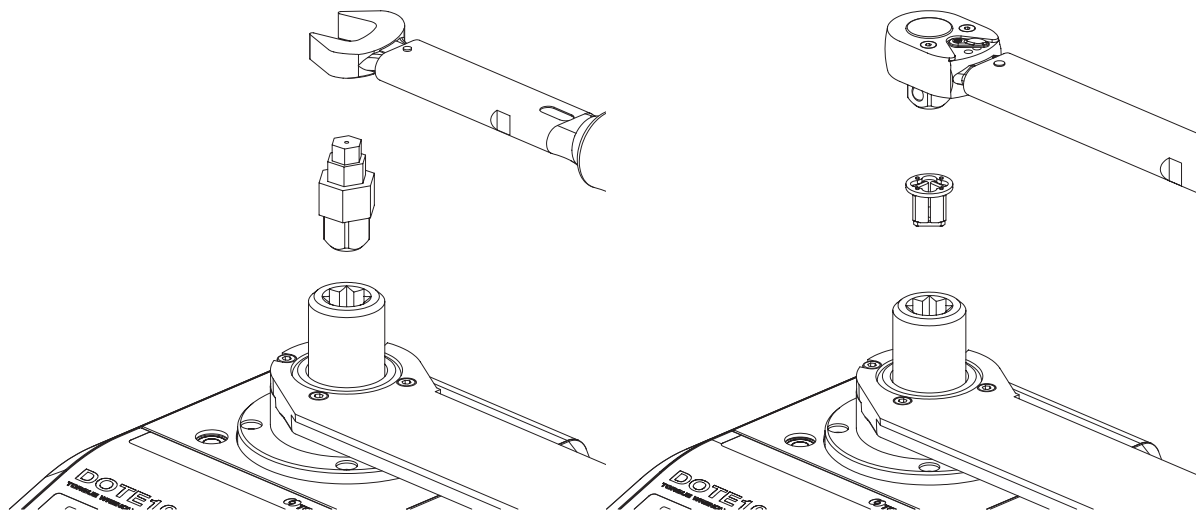

- (9) Set the measuring mode based on the torque wrench to be measured.
  - Click type (model QL, SP, etc): Peak Hold Mode (PEAK)
  - Direct-reading type (model CEM, DB, F, etc): Run Mode (RUN).
 For the setting instructions refer to section "#5. Functions and Settings".

- (10) Press the "C" key with no load to zero the tester.

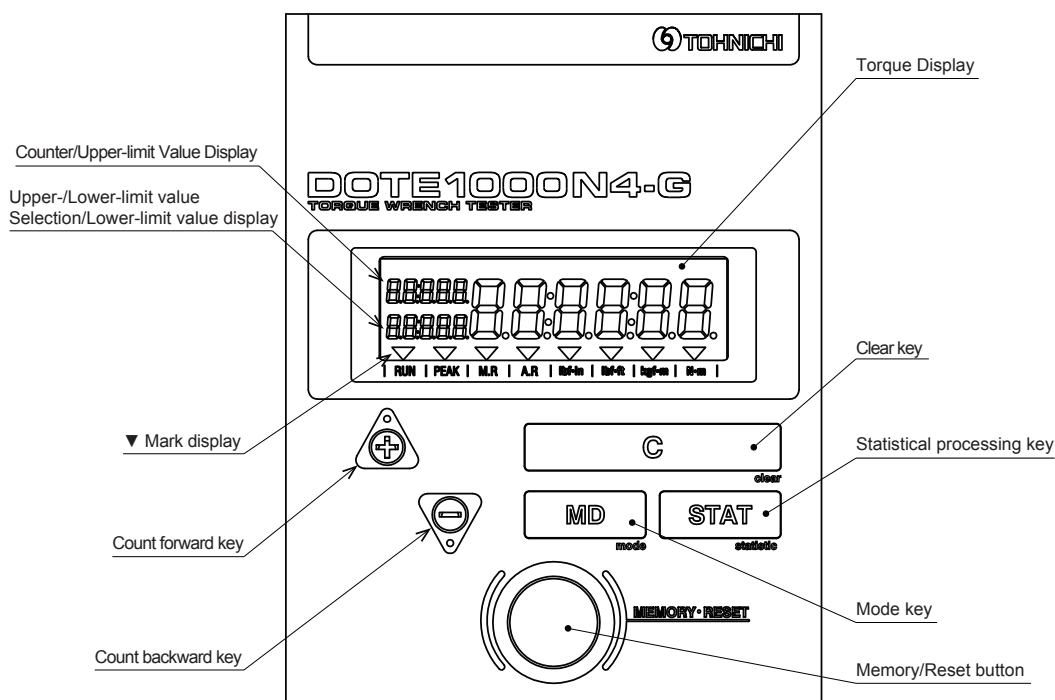

- (11) Confirm the calibration torque values of the torque wrench.
- (12) Move the Pole Holder assembly to the effective length of the torque wrench and adjust the height of the Pole Holder Plate to keep the torque wrench horizontal. Confirm the measuring stroke of the torque wrench before calibration.

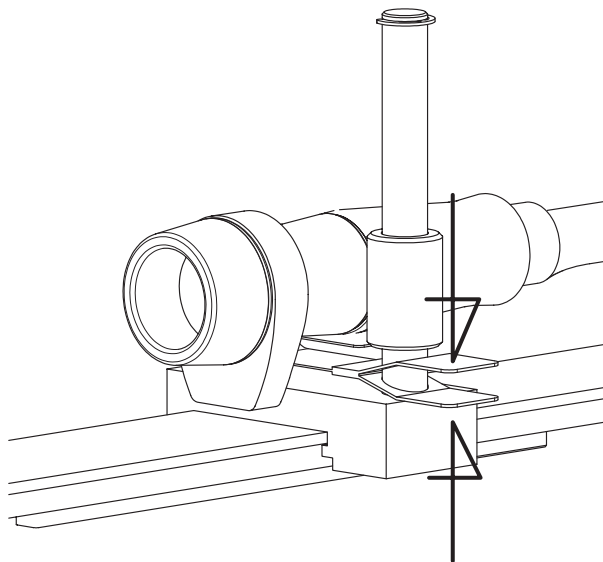
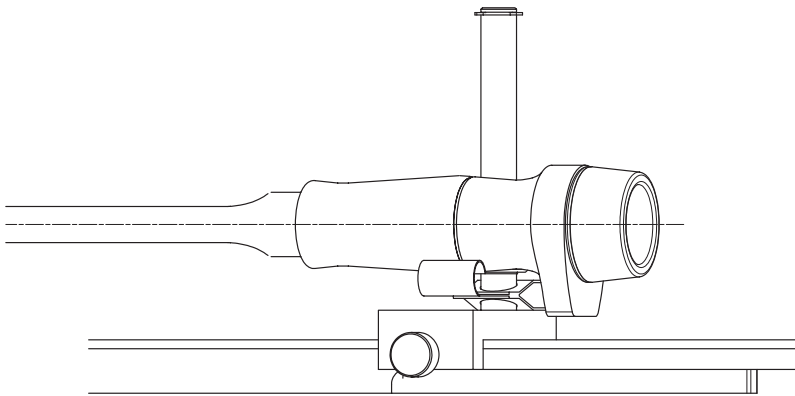
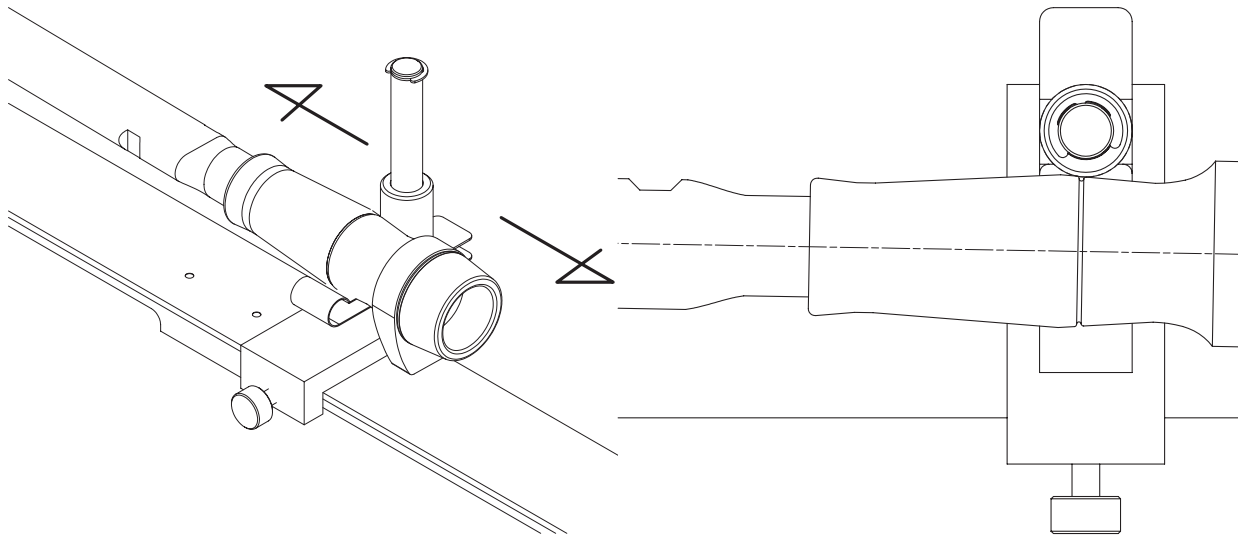

(13) Click type (QL, SP, etc):

Turn the handle of DOTE4-G till it reaches the set torque and "click".

Direct-reading type (CEM, DB, F, etc):

Turn the handle of DOTE4-G slowly till it approaches the measuring point.

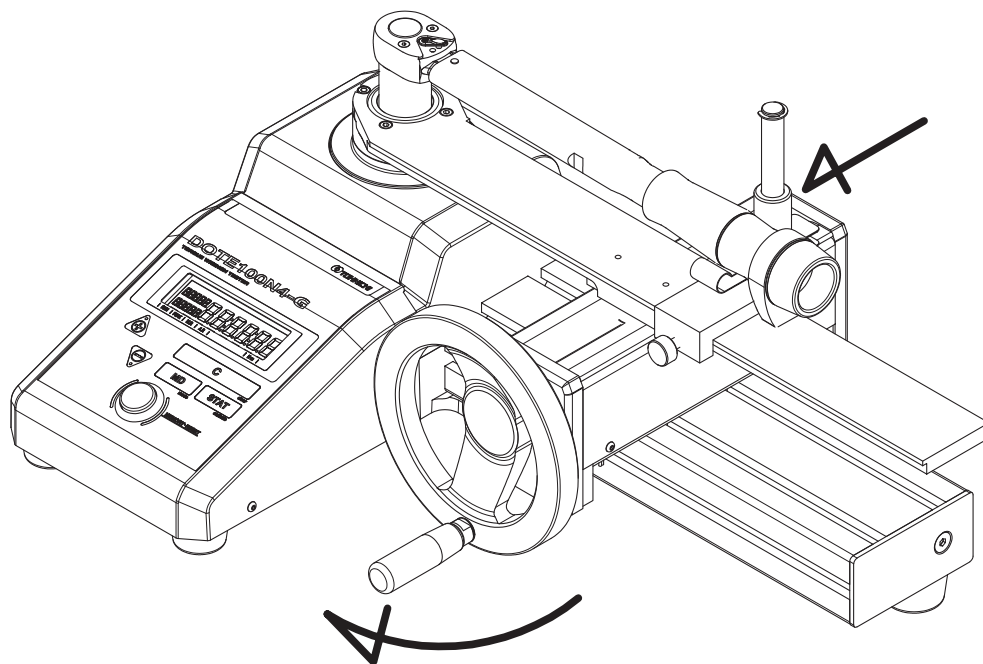

(14) Click type (QL,SP, etc):

After reaching the measuring point and "click" sound, release the loading.

If you select manual operation, press "**MEMORY/RESET**" button to save the data, then it goes on to the next counter value.

If you select AUTO MEMORY/RESET, it saves the data automatically after releasing the load down to below 2% of the maximum torque of each measurement, and forward the counter to the next.

(15) Direct-reading type (CEM, DB, F, etc):

When it approaches the measuring point, press "**MEMORY/RESET**" button to save the data, and forward the counter to the next.

(16) Repeat steps (13), (14) and (15) to complete calibration.

## 8. External Output Function

### 8-1. Printer Output

Connect the DOTE4-G and the Tohnichi printer (EPP16M3) using a printer cable (Catalog No. 382). Set the communication output format to "Prn" and ensure that other communication settings are consistent with the printer.

See "5 Various Settings" for the setting methods.

\* Do not use a printer cable and a USB communication cable at the same time.

- Communication settings for the EPP16M3

Data format	: RS232C-compliant
Transmission system	: Start-stop synchronization serial
Baud rate	: 2400 bps
Data length	: 7 bits
Stop bit	: 1 bit
Parity	: None

(1) Progressive printing

Press the "**Memory/Reset**" button. In the progressive printing, the results of statistical processing are not printed. In the Auto Memory/Reset mode, the results are automatically printed out.

(2) Continuous printing

Display the last count value in the print range and press "**STAT**" key. "**Stt**" is displayed.

Using **▲** or **▼** key, display the first count value in the print range and press "**STAT**" key.

Then, press **▲** key while "**n**" is displayed.

The data, sampling number "**n**", maximum value "**HI**", minimum value "**LO**" and average value "**X**" in the specified range are printed out.

(3) Printing of only statistical processing value

Display the last count value in the print range and press "**STAT**" key. "**Stt**" is displayed.

Using **▲** or **▼** key, display the first count value in the print range and

press the "**STAT**" key. Then, press **▼** key while "**n**" is displayed.

The sampling number "**n**", maximum value "**HI**", minimum value "**LO**" and average value "**X**" in the specified range are printed out.

- Continuous printing example for memory mode 1000

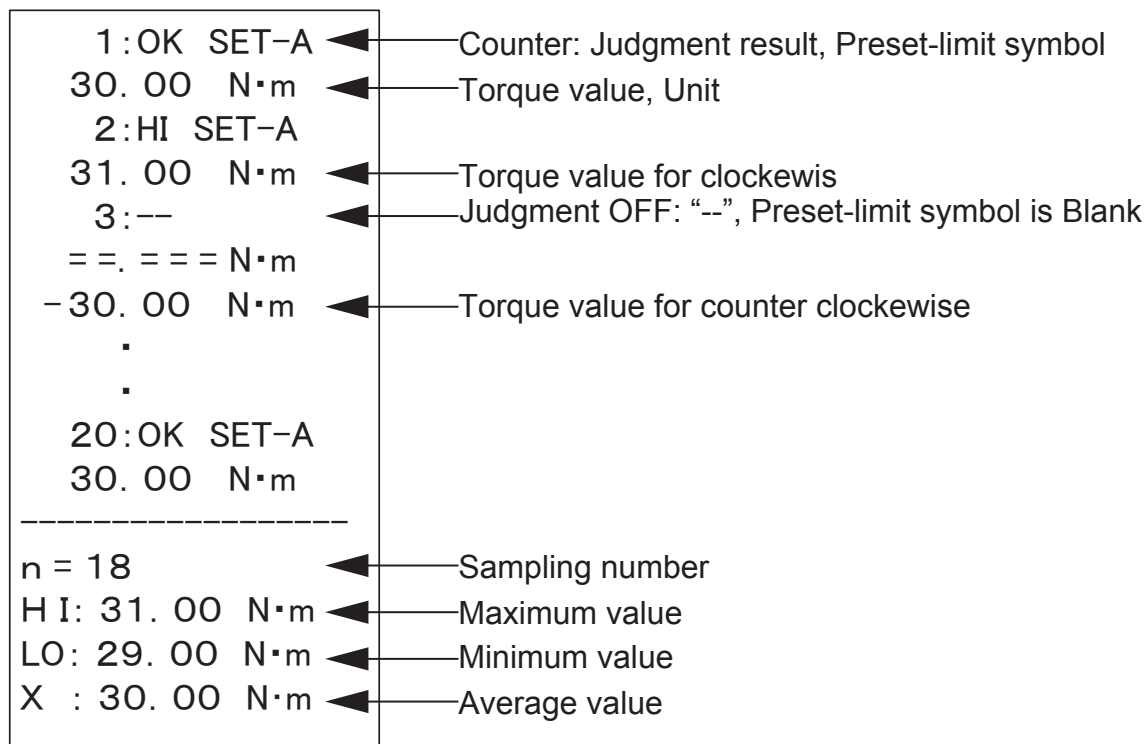

- For memory mode 99

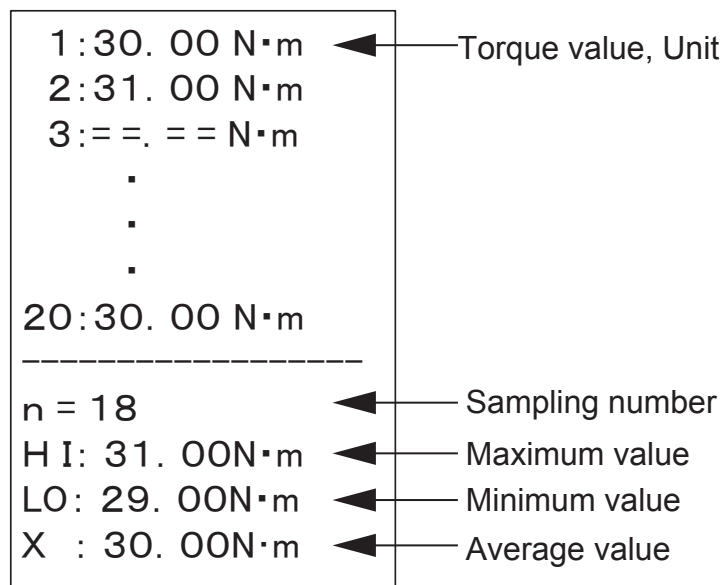

"====" denotes that the measured value displayed at the DOTE4-G is either "0" or exceeds 110%. It is excluded from statistical processing and not printed.

" - " shows in the front of calibrated value for counterclock wise measurement.

The max, min and avarage is calculated by absoluted value.

## 8-2. PC Output

Connect the DOTE4-G and an external device with a communication cable (Catalog No.383 or 385). Set the communication output format to "PC" and ensure that other communication settings are consistent with the external device. (See "5 Various Settings" for the setting methods.)

- \* Do not use an RS232C communication cable and a USB communication cable at the same time.
- \* Driver is required for communications with the No. 385 cable.  
Install the driver from the CD-R accompanying the No. 385 cable.

• Communication settings

Data format	: RS232C-compliant
Transmission system	: Start-stop synchronization
Serial Baud rate	: 2400/4800/9600/19200 bps
Data length	: 7 bits/8 bits
Stop bit	: 1 bit
Parity	: None/Even number/Odd number

### (1) Progressive output

The data are output when the "**Memory/Reset**" button is pressed or the auto memory/reset function is activated.

### (2) Batch output

Display the last memory count value in the output range and press "**STAT**" key.

"**Stt**" is displayed. Using ▼ or ▲ key, display the first memory count value in the output range and press "**STAT**" key. Then, press ▲ key while "n" is displayed.

The measured data of a selected range are collectively output.

The 7-digit of alphanumeric can be changed by command input.

Serial number of DOTE4-G is registered at shipment.

## PC Output Format

### Judgment result

- Within preset Hi/Lo value: "OK"
- Higher than preset Hi value: "HI"
- Lower than preset Lo value: "LO"
- Judgment function is off: " " Blank

• For memory mode 1000

R	E	,	0	1	2	3	,		5	0	.	0	0	0	,	n	m			,	A	,	O	K	,	1	2	3	4	5	6	A	CR	LF
				Counter 4-digit				Direction CW : " " blank CCW : " - "		Torque value 6-digit				Torque unit kgf·cm: kgfcm kgf·m:kgfm cN·m:cnm N·m:nm lbf·in:lbfin lbf·ft:lbfft				Preset symbol "A" to "J"		7-digit of alphanumeric. Default : Serial number of the body														

• For memory mode 99 (Compatible with the DOTE3-G)

R	E	,	0	1	,	5	0	.	0	0	0	,	CR	LF
				Counter 2-digit		Torque value 6-digit								

### 8-3. Operation with Communication Command

Setting of DOTE4-G can be changed by communication command from an external device. DOTE4 executes the command and sends back response command to the external device.

#### (1) Communication commands

Command	Motion
AT219,*	Switch registered upper/lower limit. * must be A:0,B:1,C:3...J:9
AT037,*****,*****	Register upper limit and lower limit at the same time. * must be torque value in 6 digits including decimal point.
AT023,*****	Register 7-digit alphanumeric. * must be upper case alphabet or number. Registered 7-digit alphanumeric is appended to measurement data.

All commands are ASCII code

Append CRLF in the end of command

#### (2) Communication example

- In case of switching upper limit setting (A)

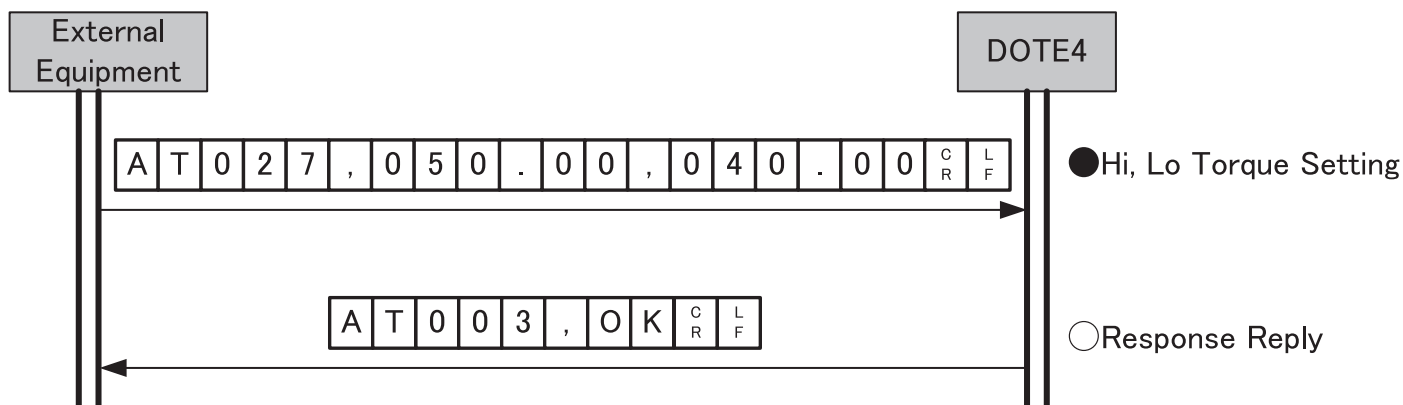

- In case of setting upper limit at 50.00 and lower limit at 40.00

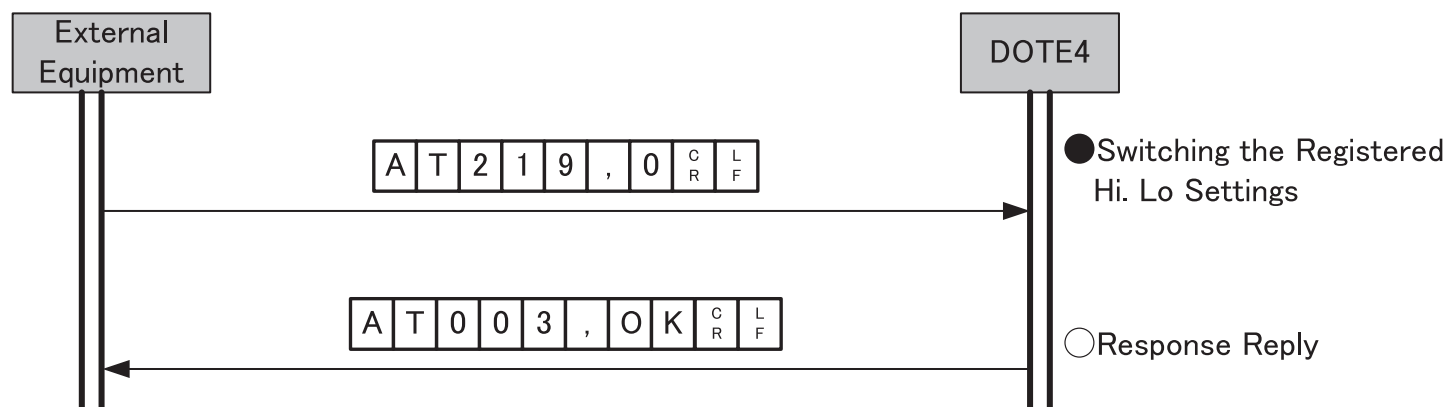

### 8-4. RS232C Output Connector Pin Assignment

The connector of DOTE4-G is D-SUB 9 Male connector

Pin No.	Signal name	Detail
1		
2	RDX	Received data signal
3	TXD	Transmitted data signal
4		
5	GND	Ground
6		
7	RTS	Request send signal
8	CTS	Clear to send signal
9		

### PC Connection Example

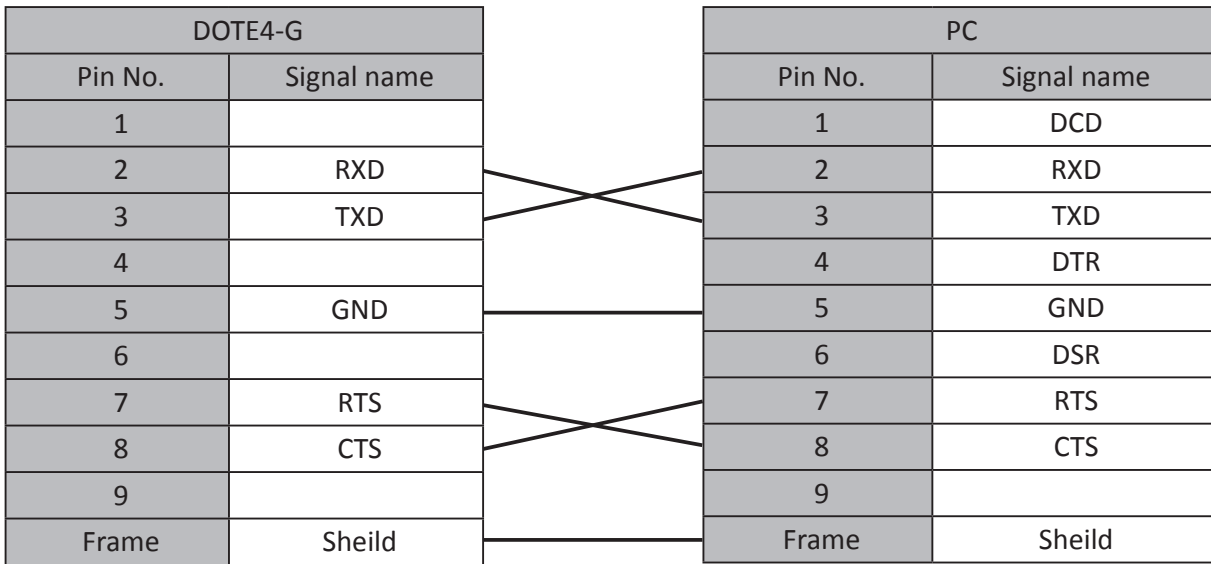



# 9. Optional Accessories

- (1) Printer . . . . . EPP16M3
- (2) Connection Cable for Printer . . . . . Part No.382
- (3) Connection Cable for PC
  - DOTE4→PC (D-SUB9 Pin Connector) . . . . . Part No.383
  - DOTE4→PC (USB B-type Cable) . . . . . Part No.385
- (4) Retrofit Motor Driven Unit
  - MD2-SET-S Applicable Model : DOTE20N4-G, 50N4-G, 100N4-G, 200N4-G
  - MD2-SET-L Applicable Model : DOTE500N4-G, 1000N4-G
  - \* Power cord will be provided in different shapes depending on each country. Contact to Tohnichi.

Complete Motor Driven Set  
 Model : DOTE20N4-G-MD2  
           DOTE20N4-G-MD2  
           DOTE50N4-G-MD2  
           DOTE100N4-G-MD2  
           DOTE200N4-G-MD2  
           DOTE500N4-G-MD2  
           DOTE1000N4-G-MD2

- (5) Calibration Kit
  - DOTCL-S1 Applicable Model : DOTE20N4-G, 50N4-G
  - DOTCL-S2 Applicable Model : DOTE100N4-G
  - DOTCL-S3 Applicable Model : DOTE200N4-G
  - DOTCL-L3 Applicable Model : DOTE500N4-G
  - DOTCL-L4 Applicable Model : DOTE1000N4-G

## 10. Error Message

Error Message	Indication	Solution
Err1 – 5	Operation key is continuously pushed.	Turn off DOTE4-G once and turn it on without touching any keys. If Err disappears, it should work properly. If Err does not disappear, it needs to be repaired. Please contact TOHNICHI or your nearest distributor.
Err8	CPU / Memory error.	It needs to be repaired. Please contact TOHNICHI or your nearest distributor.
Err9	Malfunction of the torque sensor or circuit board.	Push C key at no loading condition. If Err 9 disappears, it should work properly. If Err 9 does not disappear, it needs to be repaired. Please contact TOHNICHI or your nearest distributor.



Designs and specifications are subject to change without notice.

---

■ **TOHNICHI MFG.CO.,LTD.**

2-12, Omori-Kita, 2-Chome Ota-ku, Tokyo JAPAN

TEL.+81 3 3762 2455 FAX.+81 3 3761 3852

E-mail: [overseas@tohnichi.co.jp](mailto:overseas@tohnichi.co.jp)

Website: <http://www.global-tohnichi.com>

■ **N.V. TOHNICHI EUROPE S.A.**

Industrieweg 27, Boortmeerbeek, B-3190 BELGIUM

TEL.+32 16 60 66 61 FAX.+32 16 60 66 75

E-mail: [tohnichi-europe@online.be](mailto:tohnichi-europe@online.be)

■ **TOHNICHI AMERICA CORP.**

1303 Barclay Blvd. Buffalo Grove, IL 60089 USA

TEL.+1 847 947 8560 FAX.+1 847 947 8572

E-mail: [inquiry@tohnichi.com](mailto:inquiry@tohnichi.com)

Website: <http://tohnichi.com>

■ **TOHNICHI SALES SHANGHAI CO., LTD.**

RM.5 No.99 Nong1919, Du Hui Road, Minhang, Shanghai, P.R.China

TEL.+86 21 3407 4008 FAX.+86 21 3407 4135

E-mail: [sales@tohnichi-sh.com](mailto:sales@tohnichi-sh.com)

All right reserved. No reproduction or republication without written permission.

© TOHNICHI Mfg. CO., LTD. All Rights Reserved.

11.17.EN.