

PSC-SF30NG/PSC-SF34NG Pyrometer Series Fiber Optic Pyrometer for Glass Industry



- Wide Temperature range from 600°C to 1800°C
- Loop-powered sensor with 4-20mA output (PSC-SF30NG)
- Simple installation and operation
- High accuracy
- Robust air purge design for maintenance-free operation
- Digital RS485 communication (PSC-SF34NG)
- Integrated peak picker

Digital pyrometers PSC-SF30NG / PSC-SF34NG are especially designed for applications in the glass industry. These pyrometers are ideal for temperature measurement in glass tanks, forehearths and feeders.

The robust cast housing with flanged tabs allows for ease of installation and can be located up to 98ft (30m) from the optical lens assembly. The special mono fiber optic cable is rated for ambient temperatures of up to 482°F (250°C).

A rugged stainless steel air purge with mounting bracket and either an alumina or inconel sight/target tube assembly allows for operation in dirty environments. The optical lens can be easily cleaned or replaced.

The PSC-SF30NG produces a linear 4-20mA output

signal that can be easily incorporated into existing measurement and control systems.

The PSC-SF30NG is equipped with a USB interface, while the PSC-SF34NG features an RS485 interface connection. IR sensor parameters such as emissivity, sub range, response time and peak picking can be easily adjusted by the PSCConnect software.

Typical application areas:

- Glass temperature measured
 - in forehearth
 - in feeder
 - in glass tank
 - gobs
- Temperature measurement of refractory
 - tank side and bridge walls
 - in regenerator/throat area
 - melt tank crown

TECHNICAL SPECIFICATIONS FOR PSC-SF30NG/PSC-SF34NG

TYPE	PSC-SF30NG	PSC-SF34NG
Technical Data		
Temperature range	600°C to 1800°C	800°C to 2500°C
Sub temperature range	adjustable temperature range, minimum span 51°C	
Spectral range	0.8 μm to 1.1 μm	
Optics	FOH-G, aperture diameter D=0.43"(11mm)	
Distance ratio	> 100:1	
Measurement uncertainty	0.3% of measurement value (T _U =23°C, ε =1,t95 =1s)	
Repeatability	0.1% of measurement value (T _U =23°C, ε =1,t95 =1s)	
NETD ¹	0.1°C (T _U =23°C, ε =1,t95 =1s)	
Response time (t95)	< 10ms, adjustable up to 10s	
Emissivity	0.05 bis 1.00, adjustable	
Storage	maximum value storage, adjustable via communication interface	
Output	4...20 mA, temperature linear, max. burden: 700Ω at 24V	
Interface	galvanically isolated USB interface	RS485, half duplex, galvanically isolated
Aiming	none	
Software	PSCConnect for Windows®	
Parameters	adjustable via interface and software (emissivity, response time, temperature unit °C or °F, storage, sub range, test signal 12 mA)	
Power supply	24V DC ± 25%	24V DC ± 25%
Power consumption	max 0.6 W	max 1.5 W
Operating temperature	0°C to 70°C (pyrometer), up to 250°C (fiber cable and optical head)	
Storage temperature	-20°C to 70°C	
Weight	approx 600 g (without fiber cable and optical head)	
Dimensions	approx 4.33" x 2.76" x 1.18" (110 mm x 70 mm x 30 mm)	
Housing	Aluminum cast housing	
Safety class	IP 65 (DIN 40 050)	
CE-Symbol	according to EU regulations (EN 50 011)	
Scope of delivery	PSC-SF30NG/PSC-SF34NG, manual, inspection sheets, software PSCConnect for Windows (without connecting cable, fiber optic cable and optical lens assembly, please order separately)	
Accessories, mechanical, electrical and optical¹		
Connecting cable 3-pin	Length 16.4'(5m), 32.8'(10m), 49.2'(15m), 65.6'(20m). 82.0'(25m), or 98.4'(30m) (for SF-30NG)	
Connecting cable 12-pin	Length 16.4'(5m), 32.8'(10m), 49.2'(15m), 65.6'(20m). 82.0'(25m), or 98.4'(30m) (for SF-34NG)	
USB-connecting cable	Length 5.9'(1.8m) (for SF 30NG)	
Fiber cable (stainless steel sheathed)	Length 16.4'(5m), 19.7'(6m), 24.6'(7.5m), 32.8'(10m), 49.2'(15m), 65.6'(20m) or 98.4'(30m)	
Power supply	24 VDC/1A	
Air purge unit for FOH-G	without sight tube, incl. mounting angle	
Air purge unit for FOH-G	with inconel sight tube, 5.5"(140mm), incl. mounting angle	
Air purge unit for FOH-G	with inconel sight tube, 23.6"(600mm), incl. mounting angle	
Air purge unit for FOH-G	with ceramic sight/target tube, 11.8"(300mm), incl. mounting angle	
Air purge unit for FOH-G	with ceramic sight/target tube, 23.6"(600mm), incl. mounting angle	

PYROSPOT PSC-SF30NG and PSC-SF 34NG with fiber cable for application in glass industry

Optics type FOH-G (Order number 3310A50090)

Measuring distance a [mm]	0	500	1000	2000	3000	4000	5000
	Measuring field diameter M [mm]						
PSC-SF30NG (600 °C to 1800 °C)	11.0	10.7	10.5	10.0	20.0	31.0	42.0
PSC-SF34NG (600 °C to 1800 °C)	11.0	10.7	10.5	10.0	20.0	31.0	42.0

Dimensional drawing FOH-G

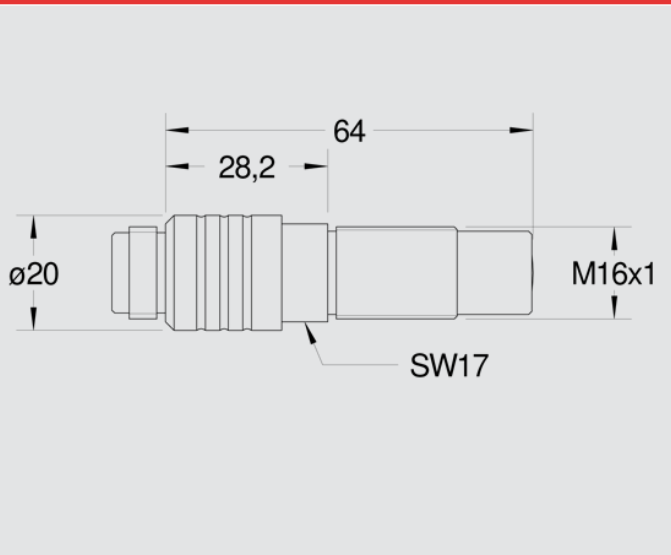

Measuring field optics FOH-G

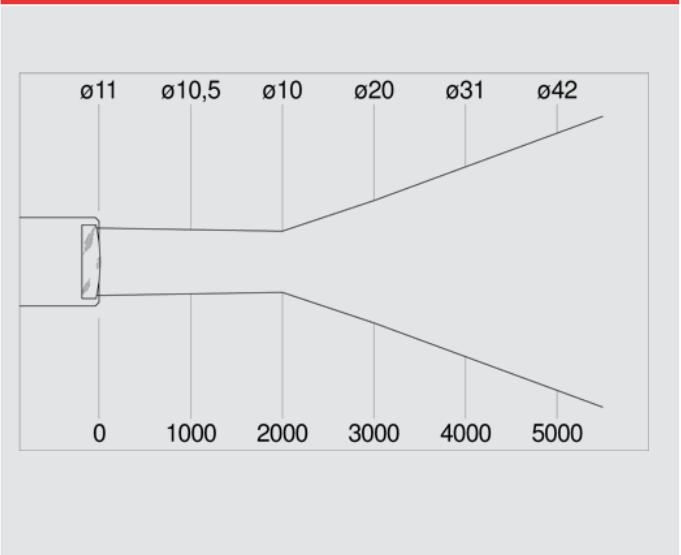

Inside view pyrometer

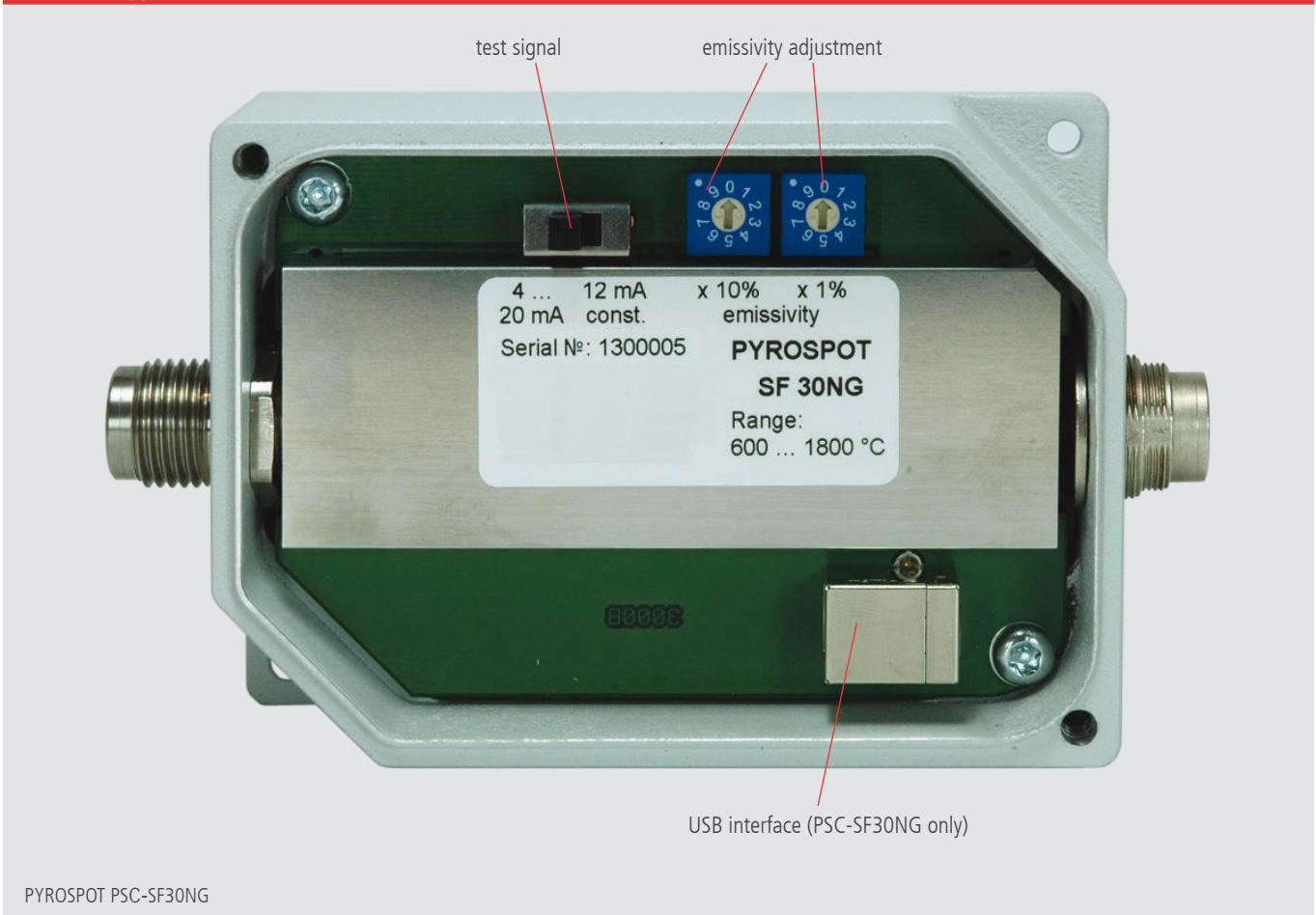

Dimensions, accessories and applications

Pyrometer Dimensions

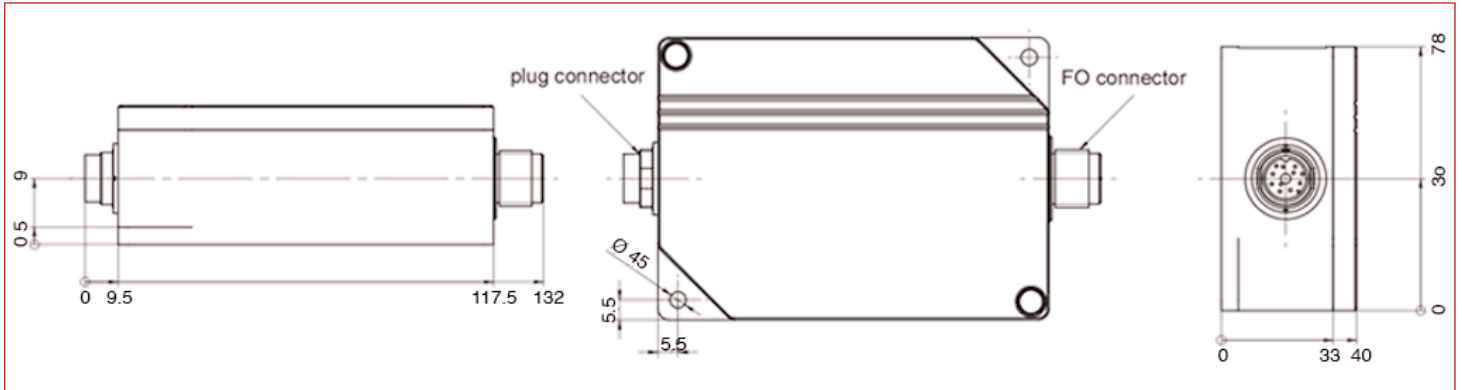

Accessories

Mounting angle with air purge assembly

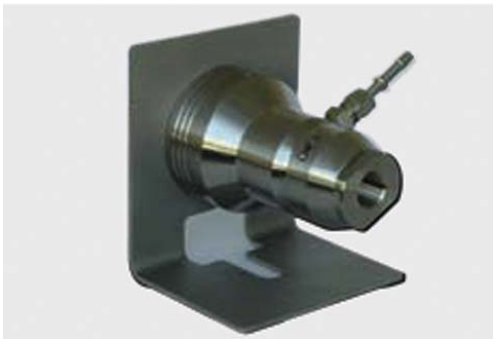

Mounting angle with air purge and inconel tube



Typical applications for the PSC-SF30NG/PSC-SF34NG Pyrometers

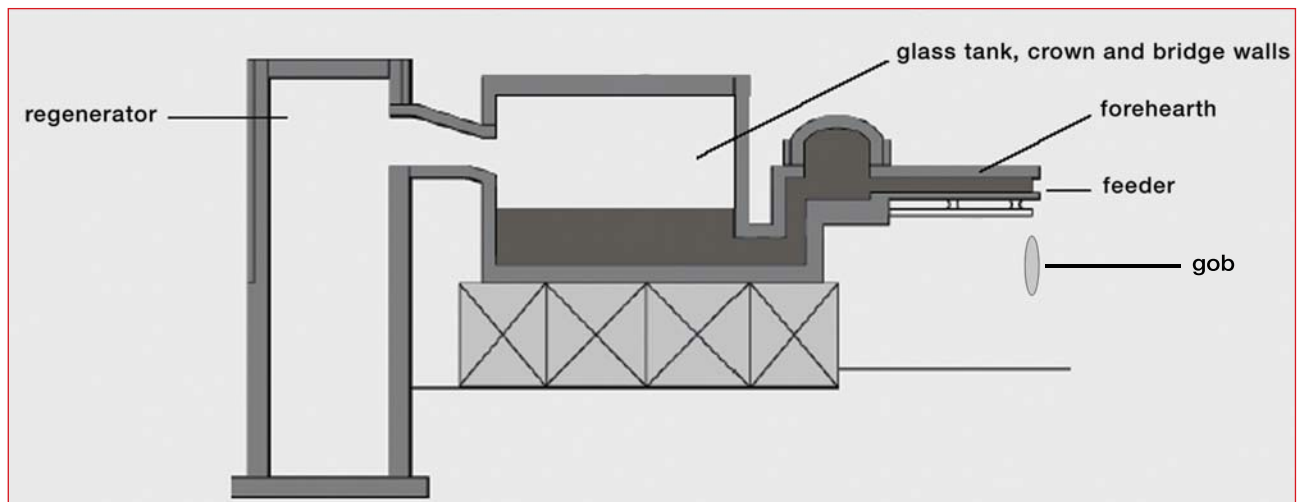

PROCESS SENSORS CORPORATION

787 Susquehanna Avenue, Franklin Lakes, NJ USA • Tel: 201-485-8773 • Fax: 201-485-8770 • www.ProcessSensorsIR.com • irtemp@processsensors.com
Headquarters: 113 Cedar Street, Milford, MA USA • Tel: 508-473-9901 • Fax: 508-473-0715