

PSC-PC and PSC-PE Series

Self-Contained Non-Contact IR Temperature Sensors



- Temperature range: -20°C to 500°C
- Choice of precision optics for large or small targets at short or long distances
- Fast response with high stability
- Compact stainless steel housing
- Quick and easy installation
- Wide range of accessories

The Process Sensors IR Compact Pyrometer Series is a group of high quality, low cost non-contact sensors that measure the temperature of moving objects and low reflective materials. All models conform to industrial EMC standards.



PSC-PC with indicator

The **PSC-PC** is a simple infrared temperature sensor with a choice of analog outputs. No complicated setup is required -just connect a temperature indicator and power supply, and instantly start taking measurements.

- Suitable for non-contact temperature measurement on most non-reflective non-metal surfaces, such as paper, thick plastics, asphalt, painted surfaces, food, rubber and organic materials, among many others.
- **Linear** analog two-wire 4-20 mA output for measured temperature



PSC-PE with PSC-Tune emissivity adjuster

The **PSC-PE** is a simple sensor with an adjustable emissivity setting.

- Two-wire 4-20 mA output
- Emissivity adjustment via a separate two-wire 4-20 mA input
- Adjust the emissivity continuously during the process using a variable 4-20 mA source
- Set the emissivity manually with optional PSC-Tune emissivity adjuster

GENERAL SPECIFICATIONS - IR SENSORS

Models PSC-PC and PSC-PE

Model Output Selection (see Model selection guide)	IR Sensor Temperature Output
- 0 (PSC-PC and PE only)	4-20 mA linear

	PSC-PC	PSC-PE
Output	Two-wire 4-20 mA	
Temperature Range	HT = 0 to 500 °C (32 to 932°F) MT = 0 to 250 °C (32 to 482°F) LT = -20 to 100 °C (-4 to 212°F)	
Accuracy	±1% of reading or ±1°C whichever is greater	
Repeatability	± 0.5% of reading or ± 0.5°C whichever is greater	
Emissivity Setting	Fixed at 0.95	Variable 0.2 to 1.0 via continuous 4-20 mA input or optional PSC-Tune adjustment
Response Time, t₉₀	240 ms (90% response)	
Spectral Range	8 to 14 μm	
Supply Voltage	6 to 28 V DC (28 V DC max.)	
Min. Sensor Voltage	6 VDC	
Max. Loop Impedance	900 Ω (4-20 mA output)	
Output Impedance	56 Ω (voltage/thermocouple output)	-
Input Impedance	-	50 Ω
Current Draw	20 mA max. 3.2 mA @ 24 V DC)	

* Other configurations available upon request

MECHANICAL

Construction	Stainless Steel
Dimensions	18 mm diameter x 103 mm long
Thread Mounting	M16 x 1 mm pitch
Cable Length	1m (longer lengths available to order)
Weight with Cable	3.3 oz (95 g)

ENVIRONMENTAL

Environmental Rating	IP65
Ambient Temperature Range	0°C to 70°C
Relative Humidity	95% max. non-condensing

GENERAL SPECIFICATIONS - PSC-TUNE

Output	4-20 mA for emissivity adjustment of PSC-PE sensor
Supply Voltage	24 V DC (13 V to 28 V DC)
Display Format	3.5 digit LCD
Display Units	Emissivity (0.2 to 1.0) or current (4 - 20 mA)
Adjustment	Push-buttons (raise/lower/set)

MECHANICAL

Construction	Polycarbonate with gasket, transparent lid (PC) and quick release screws
Mounting	Surface
Dimensions	65 mm tall x 50 mm wide x 35 mm deep
Weight	2.5 oz (72 g)

ENVIRONMENTAL

Environmental Rating	IP65
Ambient Temperature Range	0°C to 70°C
Relative Humidity	95% max. non-condensing

Wiring Configurations

PSC-PC

Two-wire (option 0)

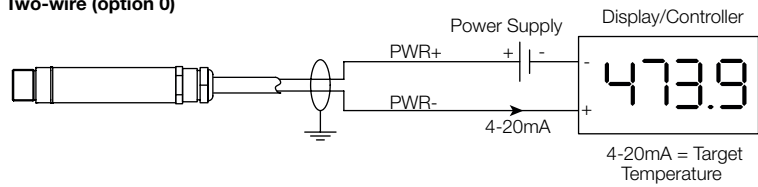

PSC-PE

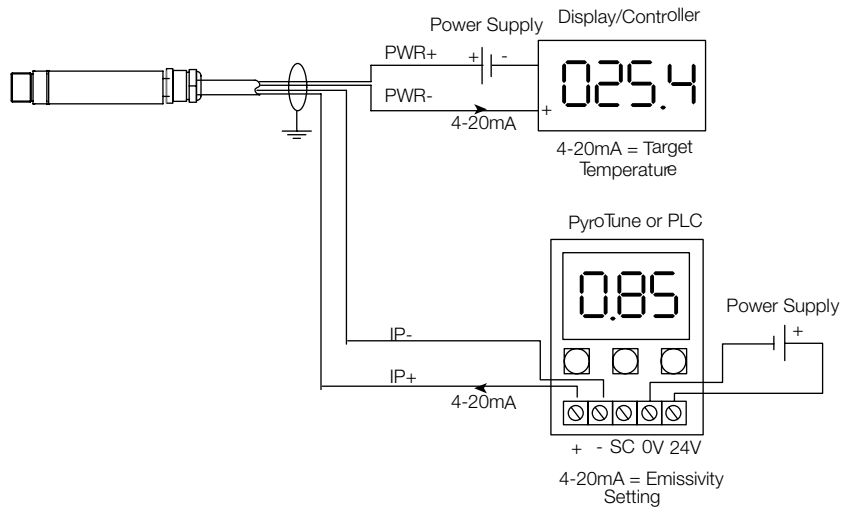

OPTICS

Distance to spot size ratio (90% energy)

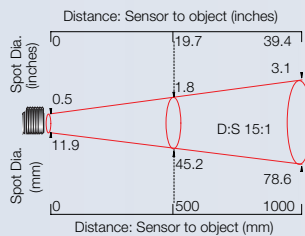

-15

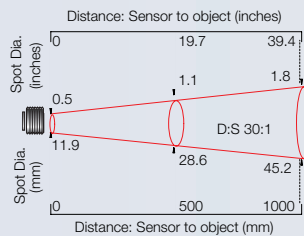

-30

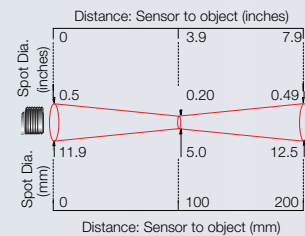

-CF

ACCESSORIES





DIMENSIONS

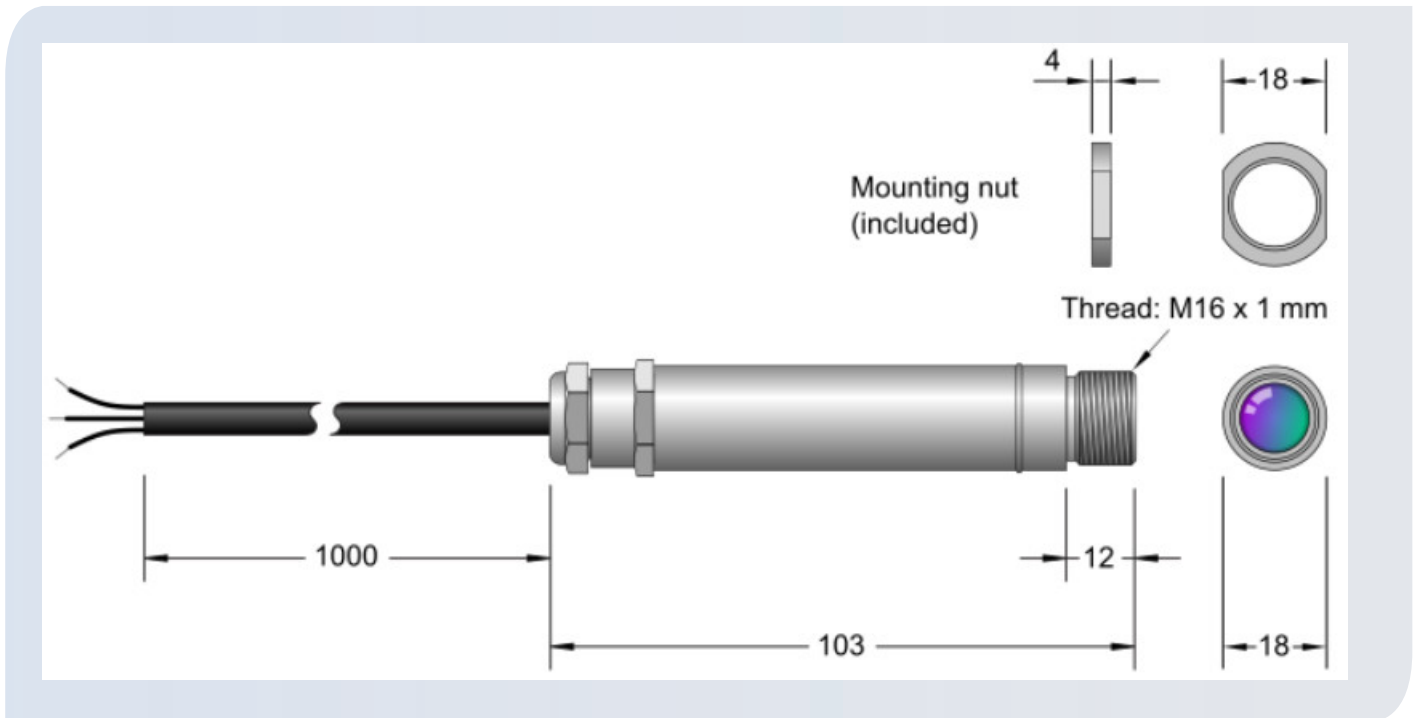

MODEL SELECTION GUIDE

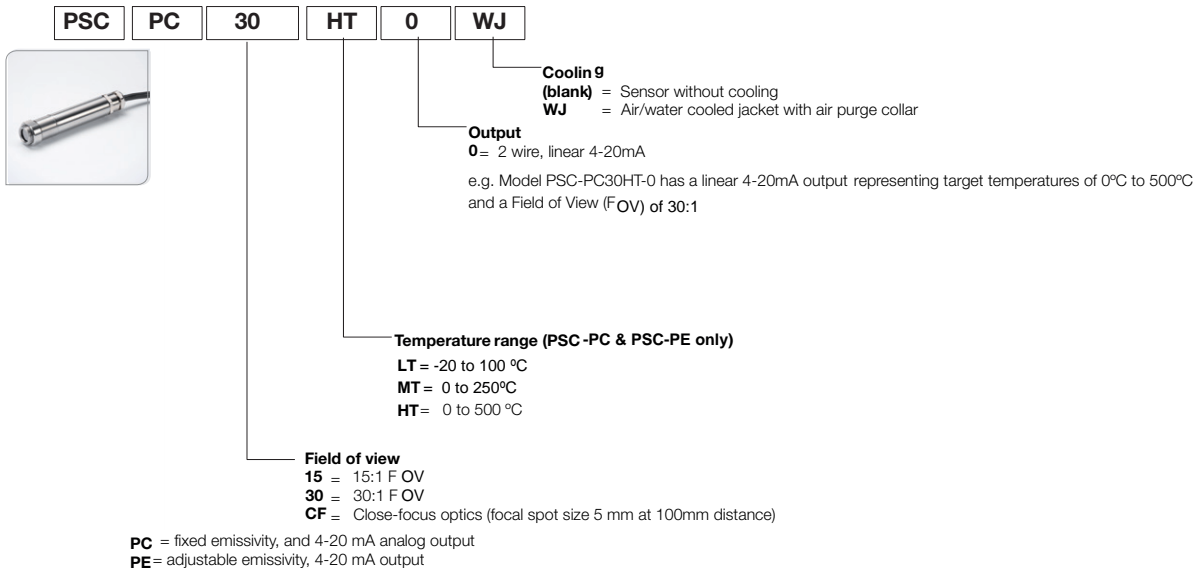

Example Model Numbers: PSC-PC30-HT-0, PSC-PE30-HT-0,

Process Sensors

787 Susquehanna Ave, Franklin Lakes, NJ 07417 USA
 Tel: 201-485-8773 // Fax: 201-485-8770
 E-mail: irtemp@processsensors.com // Online:
 www.processsensors.com

Updated: 11/6/18
 Specifications subject to change without notice