

Technical Data Sheet

Metis MY34, MY39 and MY68 "Self Contained" Pyrometer Series

Pyrometer Series *Metis MY34, MY39* and *MY68* using pyroelectrical detectors operate in a narrow band around 3.43 μm , 3.95 μm and at 6.8 μm . They were developed especially to take advantage of unusual absorption or transmission features of certain materials.

Among other reasons, standard quartz glasses also differ in their transmission properties within the short-wave infrared area. Some types of glass are available with high enough transmission at 3.43 μm to perform measurements but others are low enough to protect from unwanted radiation originating from warm sources. In semiconductor production one can find a wide application range for the *Metis MY34* product line.

To measure temperatures on thin plastic foils using a characteristic CH absorption range, e.g., polybutylene, polystyrene, polyurethane, vinyl and nylon, this series can be delivered with a lower temperature range starting from 100°C as well, should this be required by the customer.

At a wavelength of 3.95 μm hot furnace gases and clean burning gas flames are quite transparent and therefore permit temperatures of substances to be measured as well during the heating up process in industrial furnaces when using the *Metis MY39* series.

The *Metis MY68* was designed especially for close range temperature measurements of polyethylene, polypropylene, polyvinylchloride (PVC) and polystyrene above 50°C.

Chart 1: Temperature range and spectral response of different series

Model	MY34	MY39	MY68
Spectral range	3.43 μm	3.9 μm	6.8 μm
Temperature range	300 – 1300°C	150 – 1000°C 500 – 2000°C	50 – 400°C



Lenses:

The infrared energy radiated by the target is centered via focusable or fixed focus lenses directly on the detector. The focussing feature allows control of the cone of vision and offers the possibility to measure either a small spot (focused) or the average of a bigger spot (out of focus). Fixed focus lenses with larger diameter collect more infrared energy and therefore result in smaller spot sizes. The lenses are made of calcium fluoride CaF_2 which is highly transparent in visible and infrared regions up to 10 μm . If additional windows are necessary they must offer similar optical characteristics.

Chart 2: Focusable Lenses *Metis MY34*

Lens	Distance	300 – 1300°C
OM34-D0	182 mm	1.2 mm
	480 mm	2.4 mm
	780 mm	6.0 mm

Chart 3: Focusable Lenses *Metis MY39*

Lens	Distance	150 – 1000°C	500 – 2000°C
OM39-J0	150 mm	2.7 mm	1.5 mm
	400 mm	12.7 mm	4.3 mm
	580 mm	19.5 mm	8.0 mm

The detector is sensitive to infrared radiation in an area called the **cone of vision**. For the spot size diameter \varnothing of the cone of vision at shortest, medium and widest focal distances, please see **Chart 2**. For full scale temperatures up to 1300°C the cone of vision diameter in front of the lens is about 16 mm and about 9 mm for full scale temperatures above. This area has to be kept free from any intervening objects. The spot size diameter for distances not given in the chart can be calculated by interpolation.

Optical Alignment

Metis MY Pyrometers are available with 2 different solutions for aiming the sensor onto the target. The first and most popular method is the built-in laser pointer which is also helpful for focusing. The second solution is a sight-through optics version with reticle-defined target which is advantageous for applications where aiming onto hot, incandescent targets is needed. For full scale temperatures above 1800°C the viewing telescope is equipped with a dimmable sight attenuation filter to protect the eye.

Temperature Output Signals

Metis Pyrometers offer a variety of analog and digital output signals for displaying, recording, archiving and controlling of measured process temperatures. The isolated analog output is selectable from 0 to 4 - 20 mA. Zero- and full-scale temperatures are adjustable to cover any portion of the instrument's available temperature span to a minimum of 50°C.

Signal Filtering: For measuring and holding of the highest instantaneous temperature value a **peak picker** (maximum value storage) is installed to compensate interruptions or attenuations in radiation caused by bursts of steam, smoke or dust. It can be reset either automatically or manually by an external contact closure or periodically by user preset clear time. In the last case the highest temperature will be held in a dual storage and will be reset in only one of the two storages after preset clear time to avoid a decrease of the temperature output, should a short cold period appear just at the reset moment.

The **exposition time** is the length of time it takes for the output signal to reach 90% of a step change in measured temperature. It can be used to filter out rapid variations in temperature and achieve a “more quiet” signal for control or display purposes.

Software: The **PCSWin Software** is available for automatic or manual set up of the pyrometer, for recording and for saving of graphical or table files. At the same time these files can be used for quality assurance purposes because the parameter settings are recorded, too.

Minimum computer requirements: 500 MHz clock frequency and Windows 95, 98, ME or XP operating system.

Additional Specifications

Measurement Uncertainty:	1°C + 0.5% of difference between measured and housing temp. ($T_A = 23^\circ\text{C}$, $\tau = 1$, $t_{90} = 10$ s)
Repeatability:	0.1% of measured temperature in °C + 0.2°C ($T_A = 23^\circ\text{C}$, $\tau = 1$, $t_{90} = 10$ s)
Response Time t_{90} :	depending on model, 10 ms, 40 ms or 100 ms adjustable up to 10 s
Spot size diameter	Metis MY68, available on request; Metis MY34 and MY 39 see chart 2
Analog Output Signal:	0 or 4 – 20 mA selectable, max. load 500 Ω
Emissivity Range:	0.40 – 1.00
Temperature Resolution:	analog: < 0.1% of adjusted temperature range, digital 0.1°C
Ambient Temperature:	Pyrometer: operation 0 – 70°C, storage -20 – 80°C
Power Supply:	24 V AC/DC (12 – 30 V AC/DC), AC: 48 – 62 Hz, max. 2 VA
Isolation:	power supply, analog and digital output are galvanically isolated against each other and against housing
Housing and Rating:	extruded aluminium profile, IP 65 per DIN 40 050
Weight:	500 g
CE Label:	according to EU directives for electromagnetic immunity
Laser Pointer:	(optional) 650 nm, < 1 mW, class II per IEC 60825-1-3-4

Dimensions:

Metis MY with Focusable Lens and Swivel Base HA20

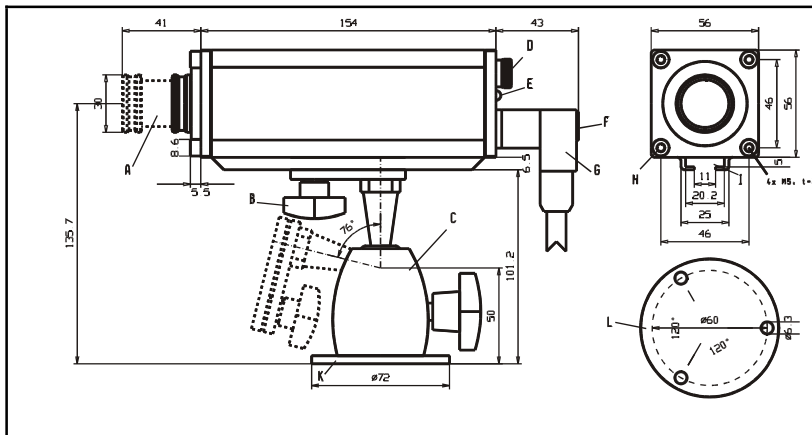

- A: Focusable Lens
- B: Fast-Mount Screw
- C: Swivel Mounting Base
- D: Eye Piece (sight-through optics)
- E: Operation LED
- F: Laser Push Button
- G: 12-pin Connector
- H: Front-Mount Threads
- I: Mounting Rail
- K: Swivel Base Mounting Flange
- L: Base View of item K with Mounting Holes
- M: Mounting Bracket

Water Cooling Jacket KG10 for use of Metis MY in hot ambient up to 200°C

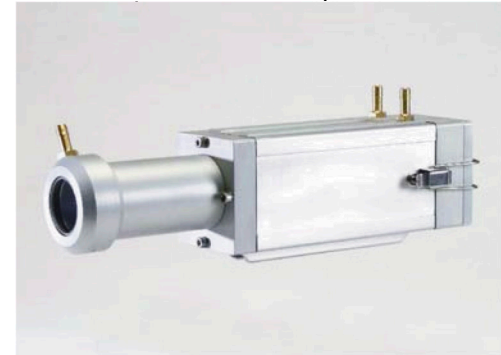

For additional accessories for mounting and protecting of *Metis* Pyrometers, please see back page of *Metis* brochure.

Metis MY with Fixed Focus Lens and Mounting Bracket HA10

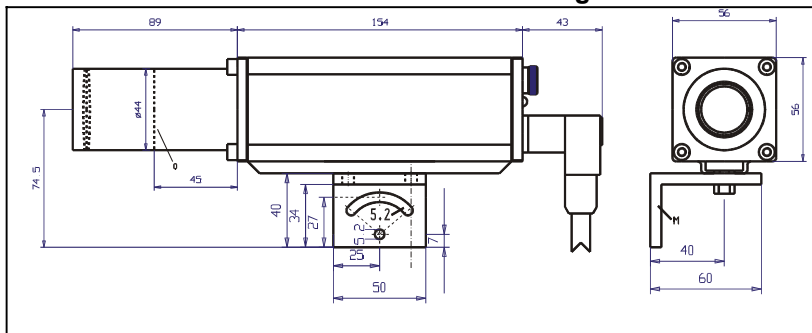

Depending on order, length of lens tube is either 45 mm or 89 mm.

Process Sensors Corporation

113 Cedar Street
Milford, MA 01757 USA

Tel: (508) 473-9901
Fax: (508) 473-0715

IRtemp@processsensors.com
www.processsensors.com