

CR-410T Tomato Package

The Right **Color** for Tomato Products



The right color of tomato products is always an indication of how fresh the product is. What is the right color? What is the right color for products such as tomato sauce, tomato paste, tomato juice and of course ketchup? In the past the “right color” judgment was purely subjective. Uniformity and consistency of color for processed tomato products is imperative from batch to batch. In order to obtain color uniformity, instrumental color measurement is necessary to insure a more consistent color batch to batch.

What is a CR-410T?

The CR-410T is a portable colorimeter, approved in December 2008, by the USDA, to measure and grade the color of processed tomato products. The CR-410T contains the specific indices formulas, needed to generate a score or grade for **tomato sauce, tomato paste, tomato juice and tomato ketchup (catsup)**.



What does the CR-410T bring to the Tomato Processing Industry?

The CR-410T brings portability, outstanding measurement repeatability and excellent inter instrument agreement. Most other instruments, approved to score tomato products, are much larger, bulky, costly and not in a portable handheld configuration. Konica Minolta Sensing instruments have a long history of providing proven and reliable color measurements to the food industry.

OTHER FEATURES:

- Ease of use
- Affordable
- Portable/Handheld
- Instrument is widely used and accepted in many other food applications
- Interface with SpectraMagic NX provides many tools for product analysis.
- On board readings

CR-410T INCLUDES:

- Chroma Meter CR-410
- Utility Software, CR-S4W
- Hard Case
- CR-A102 RS232 Cable
- 4x4 Tomato tile
- Custom Tomato Index (tomato sauce, tomato paste, tomato juice and tomato ketchup (catsup).
- Sample Cup



SpectraMagic™ NX *(optional)*

Supports Windows®2000/XP/Vista

SpectraMagic™ NX enables you to perform comprehensive color inspection and analysis of incoming raw materials, in process production, and outbound color critical goods and materials in virtually any industry. With SpectraMagic™ NX you can insert digital images with measured data. Measure samples in any of 8 universally accepted color spaces. Select from 15 illuminants, and up to 40 indices to determine specific color and appearance properties, such as strength, brightness, haze, yellowness, opacity, and strength. You can even configure up to 3 customized color equations. Reports range from simple Pass/Fail to trend charts, histograms, color plots, and spectral graphs. SpectraMagic™ NX comes with predefined templates using skin technology, or you can create your own templates. For illustrations and explanations to understanding color and color measurement technology, there is a link to Konica Minolta's well known and respected "Precise Color Communication."

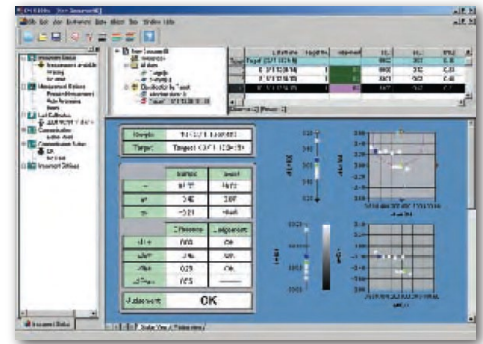

SYSTEM REQUIREMENTS

OS	Windows® 2000 Professional SP4 Windows® XP Professional SP2 Windows® Vista
CPU	Pentium® III 600 MHz or higher
Memory	128MB (256 MB recommended)
Hard Disk	450 MB of available disk space
Display	Graphic card capable of displaying 1024x768/High Color (16-bit)
Other	CD-ROM drive (required for installation) One free USB port or printer port (for protection key) One free serial port (for instrument) Internet Explorer Ver. 5.01 or later

SPECIFICATIONS

Color Space	$L^*a^*b^*$, L^*C^*h , Lab99, LCh99, XYZ, Hunter Lab, Yxy, $L^*u^*v^*$, $L^*u^*v^*$, Munsell and their color differences (excluding Munsell)
Index	WI (CIE 1982, ASTM E313-73, Hunter, Berger, Taube, Stensby, Ganz), Tint(Ganz), YI (ASTM D1925-70, ASTM E313-73, ASTM E313-96, DIN6167), WB (B ASTM E313-73), Standard Depth (ISO 105.A06), RxRyRz, Gray scale (ISO 105.A05)
Color Difference Equation	ΔE^*ab (CIE 1976), ΔE^*94 (CIE 1994), $\Delta E00$ (CIE 2000), $\Delta E99$ (DIN99), ΔE (Hunter), CMC (l:c), FMC-2, NBS 100, NBS 200
Observer	2 degree
Illuminants	C, D65
Graph Display	$L^*a^*b^*$ absolute value, $\Delta L^*a^*b^*$ (color difference distribution), Hunter Lab absolute value, Hunter ΔLab (color difference distribution), Trend chart histogram of each color space and color difference equation, Pseudo Color display

CR-400T UTILITY SOFTWARE CR-S4W

- To take measurements or change the measurement parameters of the CR-410T, you can control the unit with a PC.
- Measurement data can be transferred directly to a Microsoft Excel® file by means of the OLE Function. (Excel® 97/2000/2002 is required to use the Excel® transfer function.)
- Calibration data and color-difference reference color data can be uploaded or modified.

SYSTEM REQUIREMENTS

OS	Windows® 98/2000/XP/Vista
CPU	Pentium® 166MHz or higher
Memory	128MB (256 MB recommended)
Hard Disk	32 MB or higher
Display	VGA (640x480) or higher
Resolution	

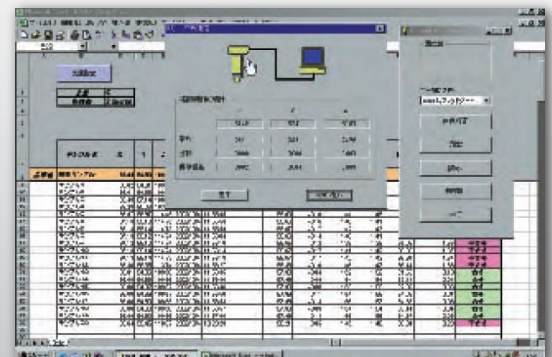

Specifications

Name	Chroma Meter Measuring Head
Model	CR-410Head
Illuminating/viewing system	Wide-area illumination/0° viewing angle (Specular component included)
Detector	Silicone photo cells (6)
Display range	Y: 0.01 to 160.00% (reflectance)
Light source	Pulsed xenon lamp
Measurement time	1 seconds.
Minimum measurement interval	3 seconds.
Battery performance	Approx. 800 measurements (when using batteries under company testing Konica Minolta's conditions)
Measurement/illumination area	φ50/φ53
Repeatability	Within ΔE*ab0.07 standard deviation (when the white calibration plate is measured 30 times at intervals of 10 seconds)
Inter instrument agreement	ΔE*ab: within 0.8
Observer	Average of 12 BCRA series II colors
Illuminant *1	2 degrees Closely matches CIE 1931 Standard Observers: (x̄, ȳ, z̄)
Display *1	C, Des
Tolerance judgment *1	Chroma values, color difference values, PASS/WARN/FAIL display
Color space/ colorimetric data	Color difference tolerance (box tolerance and elliptical tolerance)
Languages	XYZ, Y x y, L*a*b*, Hunter Lab, L*C*h, Munsell (only illuminant C), CMC(l:c), CIE1994, Lab99, LCh99, CIE2000, CIE WI-Tw (only illuminant Des), WI ASTM E313 (only illuminant C), YI ASTM D1925 (only illuminant C), YI ASTM E313 (only illuminant C), User index (up to six can be registered from computer)
Storable data sets	Operating keys : English LCD : English (default) (LCD : German, French, Italian, Spanish, Japanese) *1
Color difference target colors	1000 (measuring head and data processor save different data)
Calibration channels *1	100
Display	20 channels (ch00 : white calibration, ch01 to ch19 : user calibration)
Interface	Dot-matrix LCD with back light (15 chars x 9 lines + 1 line for icon display)
Power source	RS-232C compliant (for data processor/PC) * Baud rate : 4800, 9600, 19200 (bps), set at 9600 bps when shipped from factory
Size	4 AAA size alkaline or Ni-MH batteries, AC adapter (AC-A17) AC120V ~ 50-60Hz 0.4A (for N.America and Japan) AC230V ~ 50-60Hz 0.4A (for worldwide except N.America)
Weight	102(W) x 244(H) x 63(D)mm Approx. 570g (including 4 AAA size batteries and not including RS-232C cable)
Operating temperature/humidity range	0 to 40°C, relative humidity 85% or less (at 35°C) with no condensation * Operating temperature/humidity range of products for North America : 5 to 40°C, relative humidity 80% or less (at 31°C) with no condensation
Storage temperature/humidity range	-20 to 40°C, relative humidity 85% or less (at 35°C) with no condensation
Other	LCD back light ON/OFF function (when ON, back light stays ON for 30 seconds after last key or measurement operation)

*1 indicates when connected to the Data Processor or when not set using the Data Processor or the optional software, that some of the function are not available when the measuring head is not connected.

Dimensions

Units : mm

Measuring Head C R -4 1 0

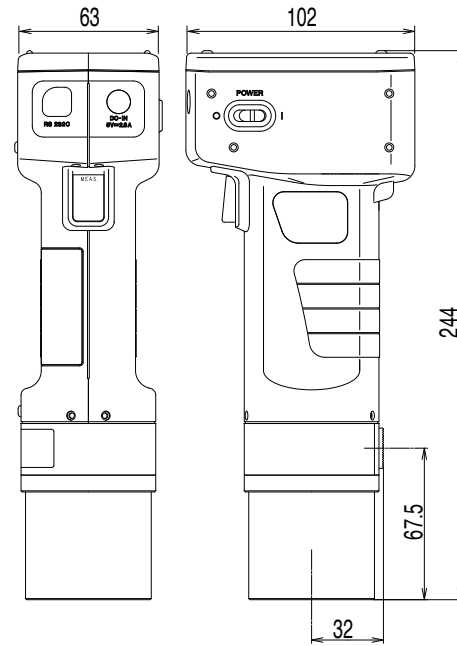

Name	Data Processor
Model	DP-400
Display range	Y : 0.01 to 160.00% (reflectance)
Measurement time *2	1 Seconds.
Minimum measurement interval *2	3 Seconds.
Battery performance	Approx. 800 measurements (when using batteries under company testing Konica Minolta's conditions)
Illuminants	C, Des
Display	Chroma values, color difference values, color difference graphs, PASS/WARN/FAIL display
Tolerance judgment *2	Color difference tolerance (box tolerance and elliptical tolerance) Only for the display function
Color space/ colorimetric data	XYZ, Y x y, L*a*b*, Hunter Lab, L*C*h, Munsell (only illuminant C), CMC (l:c), CIE1994, Lab99, LCh99, CIE2000, CIE WI-Tw (only illuminant Des), WI ASTM E313 (only illuminant C), YI ASTM D1925 (only illuminant C), YI ASTM E313 (only illuminant C), User index (up to six registered in the Measuring Head can be used)
Languages	Operating keys : English, LCD : English (default), German, French, Italian, Spanish, Japanese
Storable data sets	Max. 2000 pieces of data (divisible into 100 pages) Deletion and Undoing selected stored data (one piece of data or all data) are possible
Color difference target colors *2	Only for the operating function (100 pieces of data when the measuring head is connected; input of measurement values or numeric) (independent of page function)
Calibration channels *2	Only for the operating function (20 channels when the measuring head is connected) (ch00: white calibration; ch01 to ch19: user calibration)
Page function	100 pages
Display	Dot-matrix LCD with back light (16 chars x 9 lines + 1 line for icon display) Contrast adjustment
Printer	384 dot line thermal printer (can also print graphs) Automatically prints out all measurement results (can be set not to print)
Statistical function	Maximum, minimum, average, and standard deviation
Automatic measurement *2	Date and time display: year, month, day, hour, minute Timer: 3seconds. to 99 minutes. (Some measurement modes require more than 3 seconds.)
Interface	RS-232C compliant Baud rate (bps) : 19200 fixed (when connected to PC) When measuring head is connected baud rate is automatically set to that of the measurement head
Power source	4 AA size alkaline or Ni-MH batteries, AC adapter (AC-A17) AC120V ~ 50-60Hz 0.4A (for N.America and Japan) AC230V ~ 50-60Hz 0.4A (for worldwide except N.America)
Size	100(W) x 73(H) x 255(D)mm
Weight	Approx. 600g (not including batteries and paper)
Operating temperature/humidity range	0 to 40°C, relative humidity 85% or less (at 35°C) with no condensation * Operating temperature/humidity range of products for North America : 5 to 40°C, relative humidity 80% or less (at 31°C) with no condensation
Storage temperature/humidity range	-20 to 40°C, relative humidity 85% or less (at 35°C) with no condensation
Other	User calibration function (multi-calibration/manual calibration) *2, Measurements for automatic average function, Print ON/OFF function, CR-400 measurement data import function *2, All color space print ON/OFF function, Data protection ON/OFF function, Back light ON/OFF function, Buzzer ON/OFF function, Display color limit function, Remote mode (stored data output), Character input function (alphanumeric)

*2 indicates that part of or all functions are not available when the measurement head is not connected.

Specifications are subject to change without notice.

Data Processor DP -4 0 0 (optional)

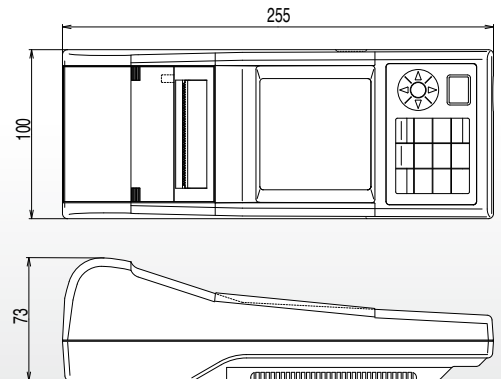

SAFETY PRECAUTIONS

For correct use and for your safety, be sure to read the instruction manual before using the instrument.
• Always connect the instrument to the specified power supply voltage. Improper connection may cause a fire or electric shock.